

I

E

O

A

Z

2025

# TABLE OF CONTENT

<b>4</b>	<b><i>Functional Modules</i></b>
<b>16</b>	<b><i>Naomi Lines</i></b>
◆	<b><i>S-Line</i></b>
◆	<b><i>Backyard</i></b>
◆	<b><i>D-Line - Outdoor</i></b>
◆	<b><i>Chameleon</i></b>
<b>27</b>	<b><i>Naomi Boxing Solutions</i></b>
<b>35</b>	<b><i>Naomi Strength</i></b>
<b>36</b>	<b><i>10x Training</i></b>
<b>47</b>	<b><i>Naomi Customs</i></b>

tiguar  
SOFT PLYO BOX

**1**  
**60 CM**



STRENGTH

ROPE

ICS

MIAMI  
FITNESS DESIGN

STORAGE

tiguan

15 KG

tiguan

15 KG

tiguan

15 KG



# NAOMI FUNCTIONAL MODULES

---

Naomi Fitness Design, we believe that true innovation in fitness comes from adaptability and customization. That's why our Functional Modules offer a revolutionary approach to gym design, allowing fitness spaces to be built and expanded with unmatched flexibility. With over 90 single training solutions, gym owners, trainers, and facility managers can create a fully personalized workout experience tailored to the specific needs of their members.

## **What are functional modules?**

Functional Modules are individual training components that can be arranged in countless combinations to fit any space, training style, or fitness level. Whether it's strength training, functional workouts, mobility exercises, or group training setups, these modules can be mixed and matched to create a unique, high-performance fitness environment.

### *1. Ultimate Customization*

With 90+ unique modules, you can design a setup that perfectly aligns with your gym's vision, client needs, and space requirements. Whether you prefer a compact, high-intensity training station or an extensive multi-functional training hub, our modular approach ensures a seamless fit.

### *2. Scalability & growth potential*

Unlike fixed gym equipment, Functional Modules allow for gradual expansion. Start with a foundational setup and add new elements over time to accommodate growing membership demands or new fitness trends.

### *3. Space optimization*

Maximize the efficiency of your gym floor by integrating modules that utilize vertical and horizontal space smartly. Whether you have a compact studio or a large fitness center, Functional Modules enable you to make every square meter count.

### *4. Versatility in training*

From pull-up bars and dip stations to agility components and strength-building solutions, Functional Modules support a wide range of training styles. This makes them ideal for functional training, HIIT, calisthenics, strength workouts, and even rehabilitation exercises.

### *5. Easy adaptation to member needs*

Fitness trends are constantly evolving, and one-size-fits-all gym setups quickly become outdated. With Naomi Functional Modules, you can modify your gym's layout to match changing trends and client demands without the need for expensive renovations.

### *6. Seamless integration with other Naomi's solutions*

Our Functional Modules are designed to be fully compatible with Naomi Lines, Strength Line, Boxing Solutions, Outdoor Solutions, and Full Gym Setups. This ensures effortless expansion and harmonious design integration.

### *7. Durability & quality*

All our modules are crafted from high-grade materials, ensuring exceptional durability under intense use. Designed and manufactured in Poland, our modules adhere to EU quality standards, guaranteeing long-lasting performance and reliability.

1



*Base Frame*

2



*Low Calisthenics*

3

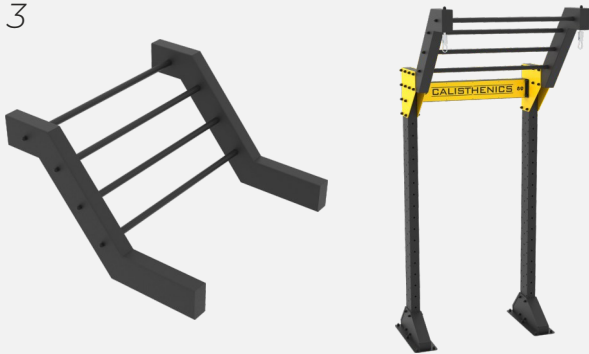

*High Calisthenics*

4



*Boxing Bag 180cm*

5



*Boxing Bag 160cm*

6



*Customized Boxing bag*

7



*Aqua Bag*

8

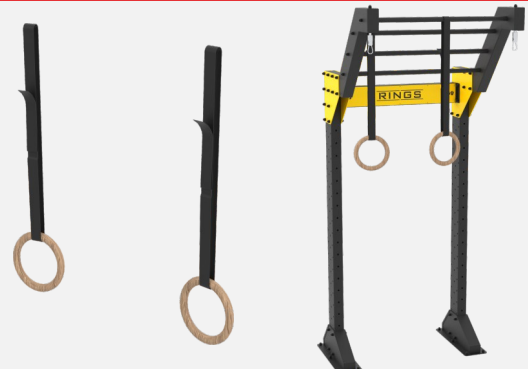

*Gymnastic Rings*

9



*Ball Target ( or custom logo )*

10



*Double Target Ball Straight*

11

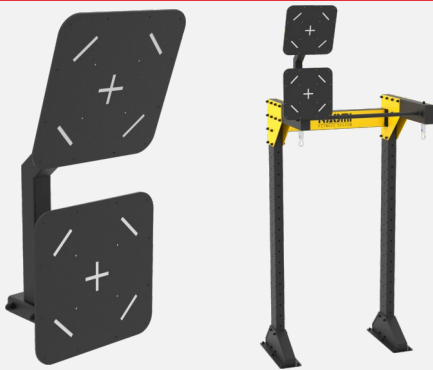

*Double Ball Target*

12



*Peg Board Vertical*

13



*Peg Board Horizontal*

14

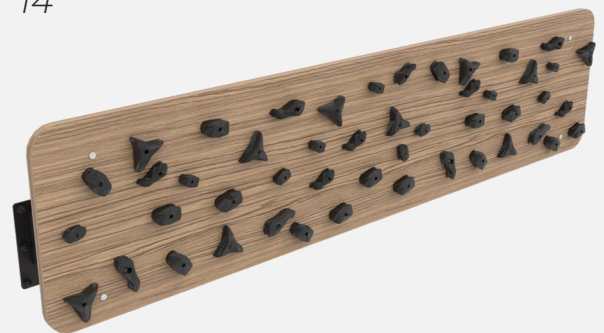

*Large Climbing Board*

15



*Large Combo Climbing*

16

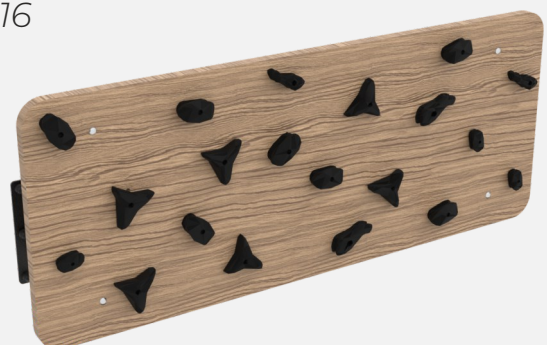

*Climbing Board Horizontal*



17



*Climbing Board with Rope*

18



*Endless Rope*

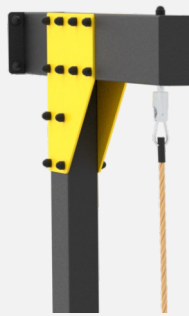

19



*Climbing Rope*

20

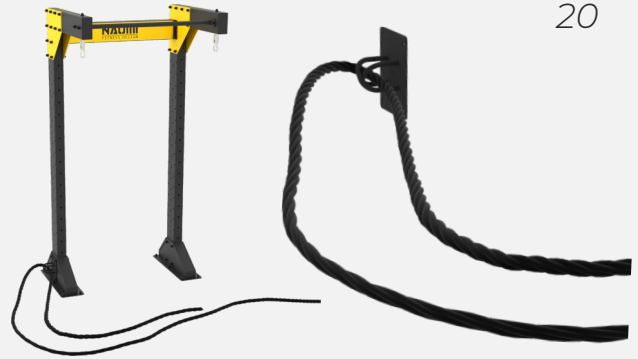

*Battle Rope*

21



*Landmine*

22

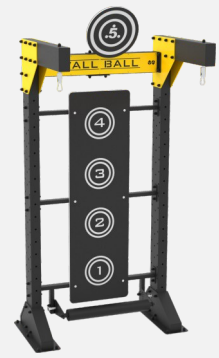

*Wall Ball 100*

23

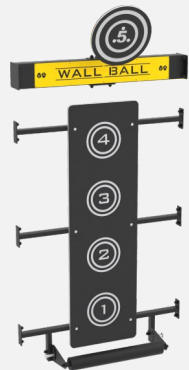

*Wall Ball 120*

24

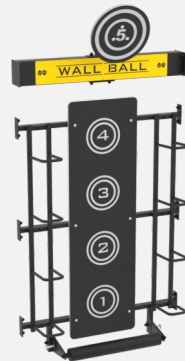

*Wall Ball 120+*

25



*Pull up Bar 100 | 120*

26

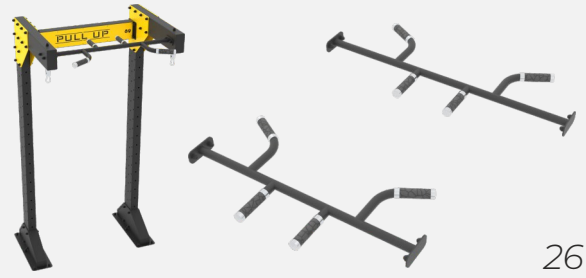

*Multigrip Pull up 100 | 120*

27



*Pull up Handles*

28

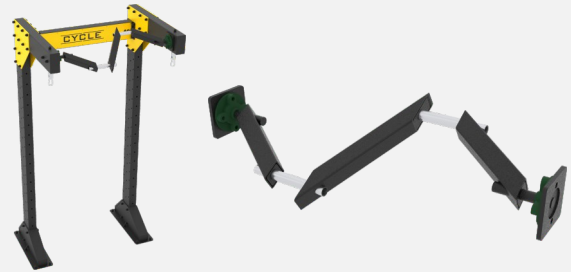

*Cycle*

29



*Rebounder*

30



*Standard Monkey Bar*

31



*Straight Monkey Bar*

32



*Wave Monkey Bar*

33



*Army net monkey Bar*

34



*Simple Dip*

35



*Dip Abdominal Throne*

36



*Indoor Jump Platform*

37



*Outdoor Jump Platform*

38



*Abdominal Bench*

39



*Bulgarian Squat*

40



*Squat*

41



*Squat+*

42



*Power Rack Station*

43



*Smith's Station*

44

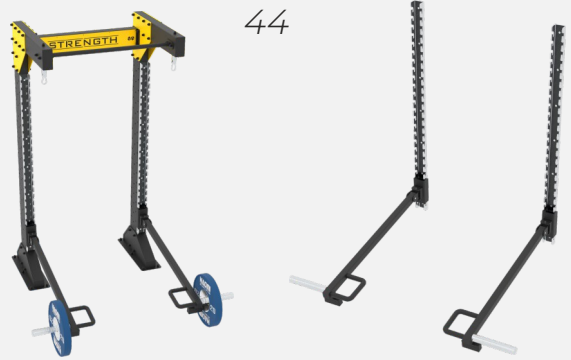

*Strength Arms*



45

*Power Arms*

46



*Wall Ball Storage*

47



*Standard Shelf Storage*

48



*Suspended Shelf Storage*



49



*Suspended Shelf Storage +*



50

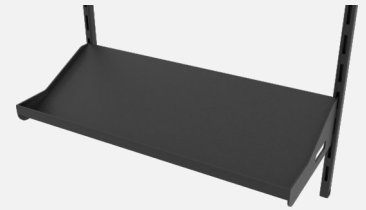

*Dumbbell Shelf Storage*



51



*Dumbbell Vertical Storage*



52



*Mat Storage*

53



*Corner Shelf Storage*

54

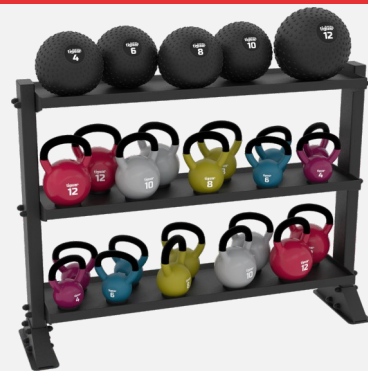

*Storage Rack*



55



*Fitness Pump Storage*



56



*Plate Holder Storage*

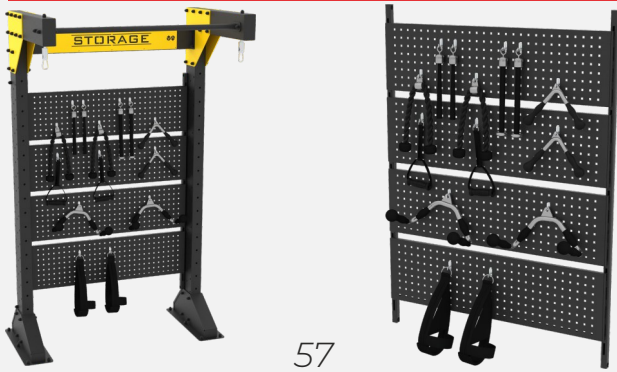

57

*PegBoard Storage*



58

*One stack*

59



*Cable Crossover*

60



*Pull Down & Low Row*

61



*Shoulder Rise*

62



*Ladder v1*

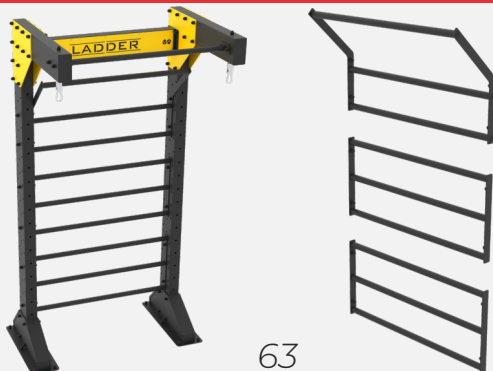

63

*Ladder v2*



64

*Wooden Ladder v1*



65

*Wooden Ladder v2*



66

*Slanted Ladder*



67

*T-Bar Station*

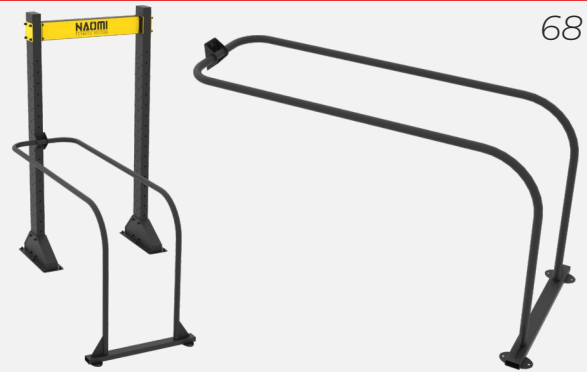

68

*Long Dip*

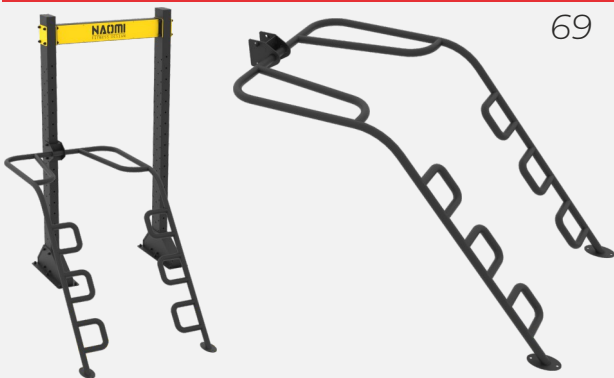

69

*Multi Push Up*



70

*Abdominal Straps*



71

*Grip Balls*



72

*Open Box Storage*

73



*Closed Box Storage*

74



*Bench Box*

75

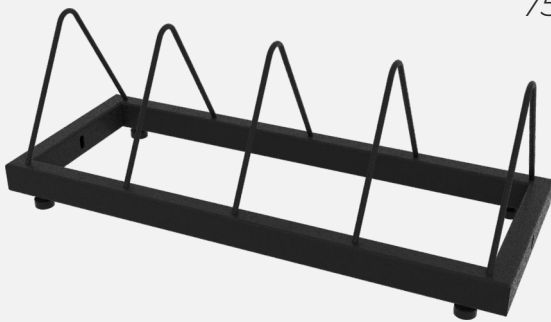

*Floor Plate Storage*

76



*Barbell Storage*

77



*Single Barbell Storage*

78



*BOSU Storage*

79



*Fitness Ball Storage*

80



*Side Mat Storage*

81



*Fixed Barbell Storage*

82



*Functional Bench*

83

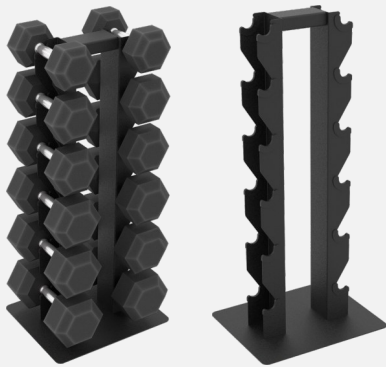

*Dumbbell Storage Rack*

84



*Adjustable Bulgarian Squat*

85



*Rail System*

86

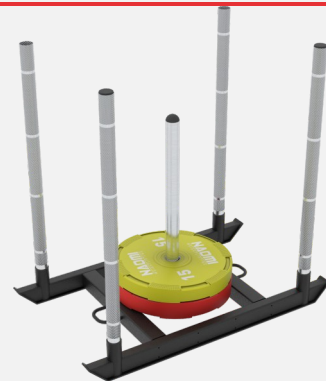

*Competition Sled*

87



*Sled*

## ***S-Line Series – Modern Training Cages for Versatile Workouts***

---

*The S-Line series from NAOMI Fitness Design consists of professional training cages designed for top-level functionality, modularity, and durability. With modern design and high-quality craftsmanship, they are ideal for both fitness clubs and outdoor training spaces. The ability to customize the color, equipment, and configuration ensures that each cage in this series meets the individual needs of users.*



**S-Line Series – S200** □ 27 m<sup>2</sup> ● 9 users

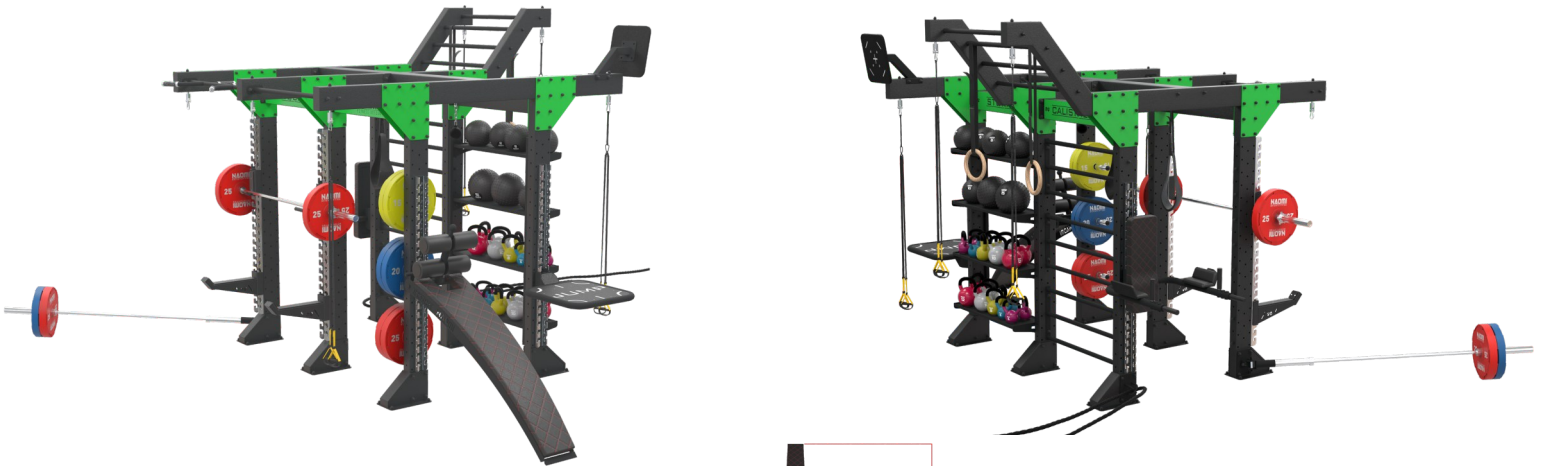

A compact cage for smaller spaces, equipped with essential training stations: pull-up bars, dip bars, and accessory holders. A perfect solution for training studios and boutique gyms. Accommodates up to 9 users simultaneously.

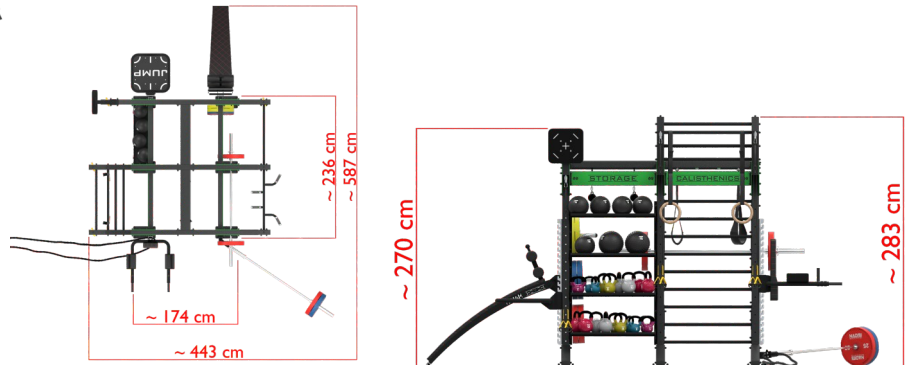

**S-Line Series – S300** □ 32 m<sup>2</sup> ● 12 users

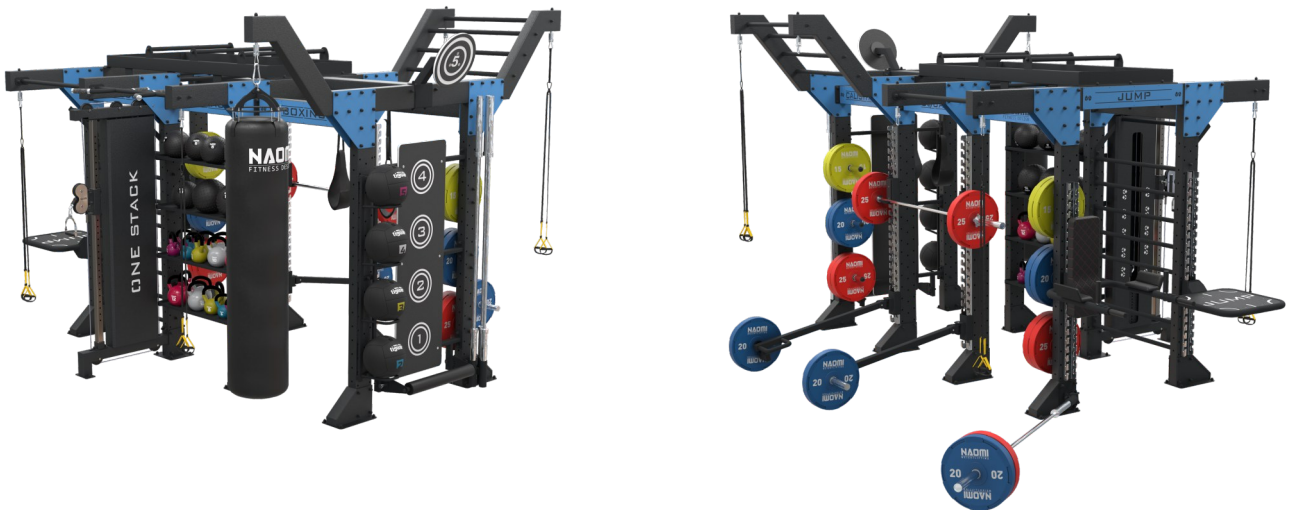

A medium-sized structure offering a greater variety of exercises. It features an expanded bodyweight training area and additional equipment storage. Accommodates up to 12 users simultaneously.

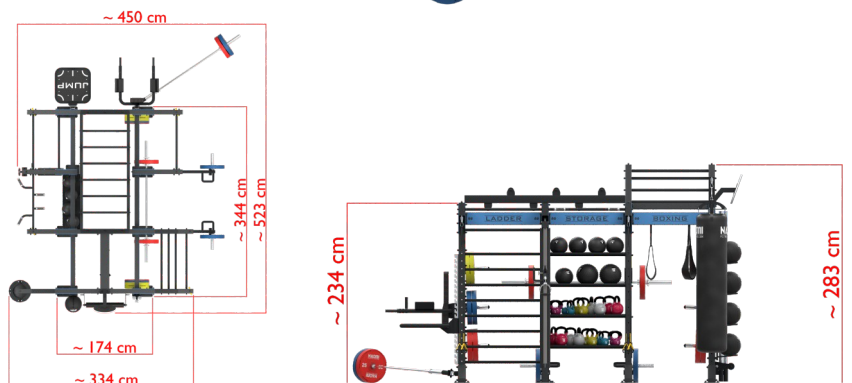

**S-Line Series – S400** 40 m<sup>2</sup> 👤 15 users



An advanced model designed for functional, strength, and group training. It includes multiple equipment holders, additional pull-up bars, and the option to mount premium accessories. Accommodates up to 12 users simultaneously.

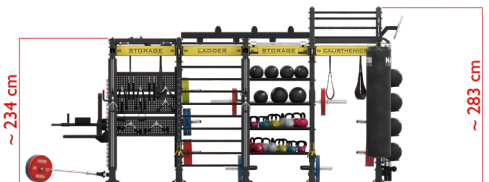
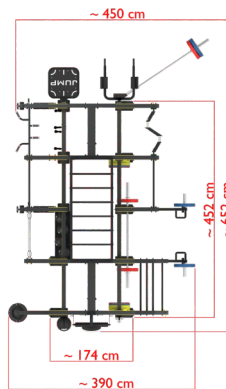

**S-Line Series – S500** 45 m<sup>2</sup> 👤 17 users



The largest and most versatile cage in the S-Line series. Ideal for large gyms, providing maximum training stations for multiple users at the same time. Perfect for professional fitness facilities and personal training centers. Accommodates up to 14 users simultaneously.

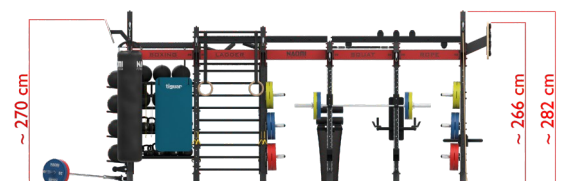
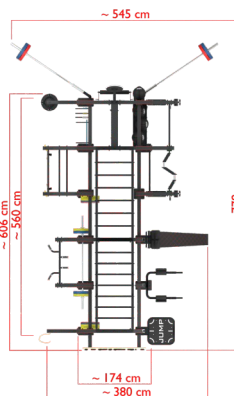

## Backyard Series – Versatile and Cost-Effective Training Structures

The Backyard series offers an economical training solution that combines maximum functionality with space efficiency. The structure allows for the placement of training stations around a single row of posts, enabling optimal space utilization. While the Backyard series is often used for outdoor training, its modular and open design also makes it ideal for indoor sports facilities and gyms.

Thanks to its flexible construction, the Backyard series can be easily adapted to different user needs. It can serve as a base for functional, strength, and endurance training. The ability to expand and mount various accessories makes it an ideal solution for fitness clubs, urban spaces, and sports centers.

### Backyard Series – Backyard 1 □ 9 m<sup>2</sup> 👤 4 users

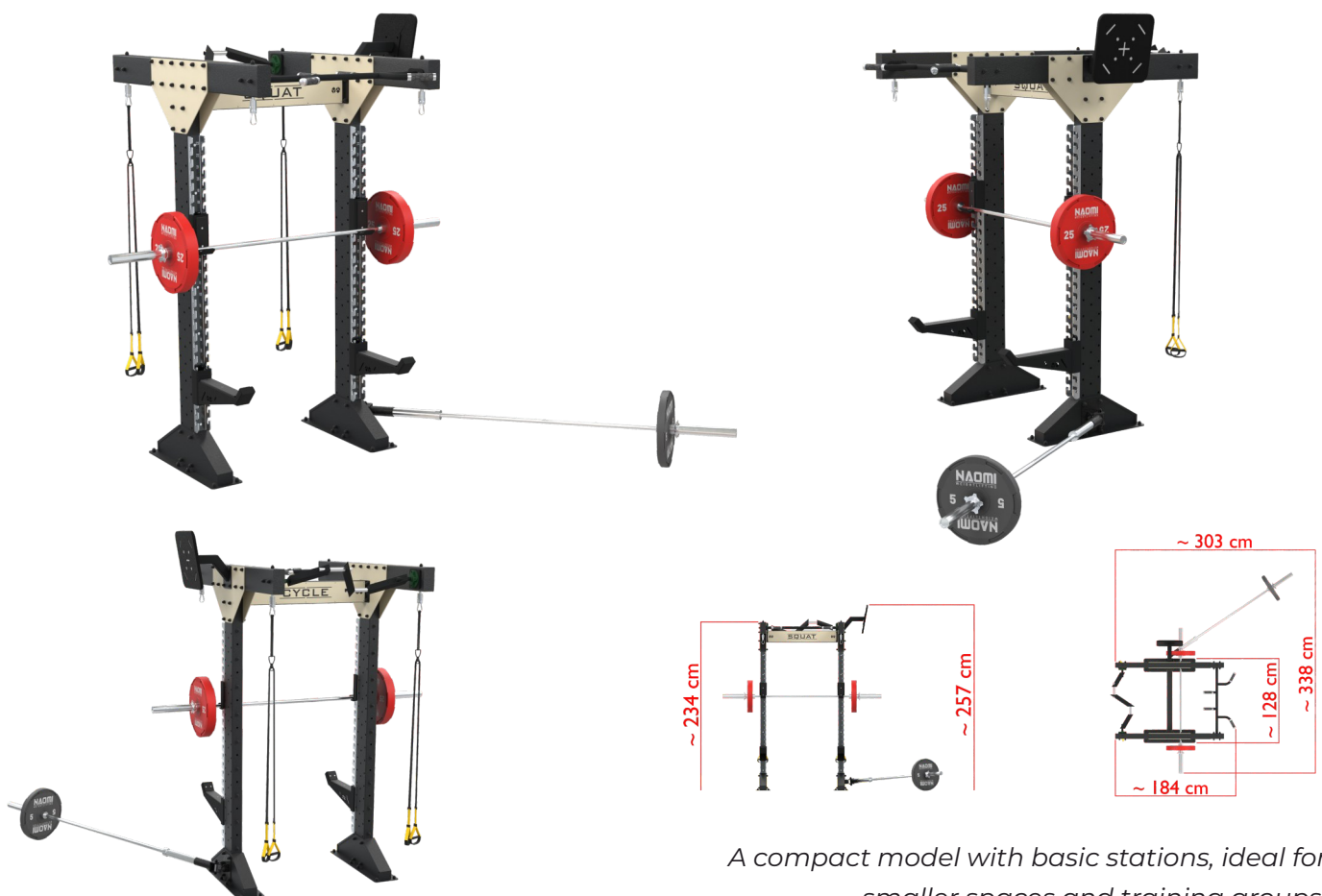

**Backyard Series – Backyard 2** 12 m<sup>2</sup> 👤 6 users

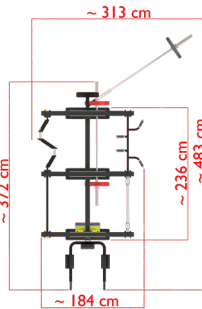
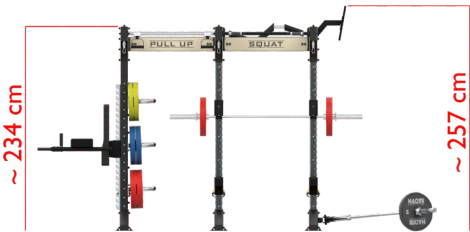
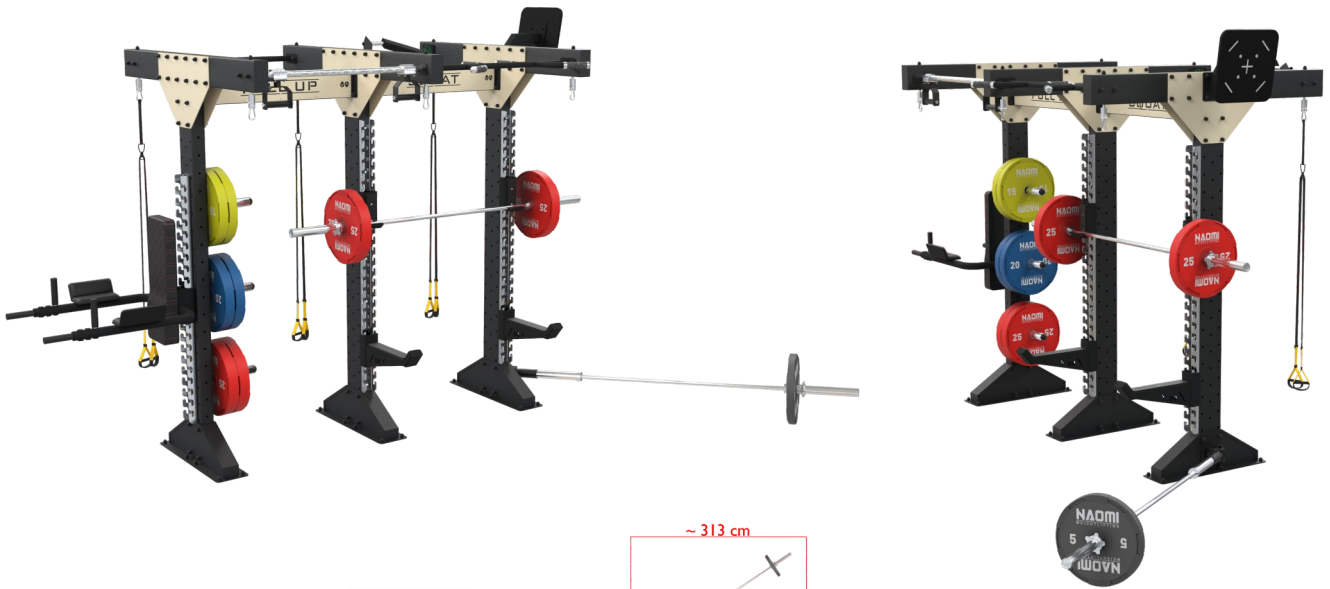

*A medium-sized structure offering more training stations on both sides.*

**Backyard Series – Backyard 3** 18 m<sup>2</sup> 👤 8 users



*An advanced version with additional grips and bars, ideal for larger groups of users.*

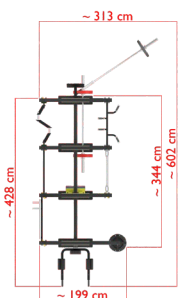
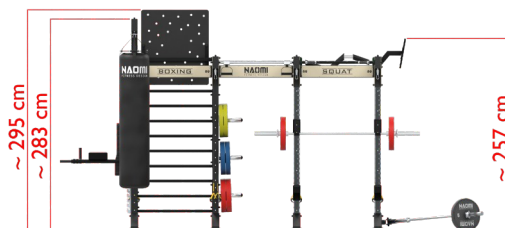

**Backyard Series – Backyard 4**   21 m<sup>2</sup> 👤 10 users

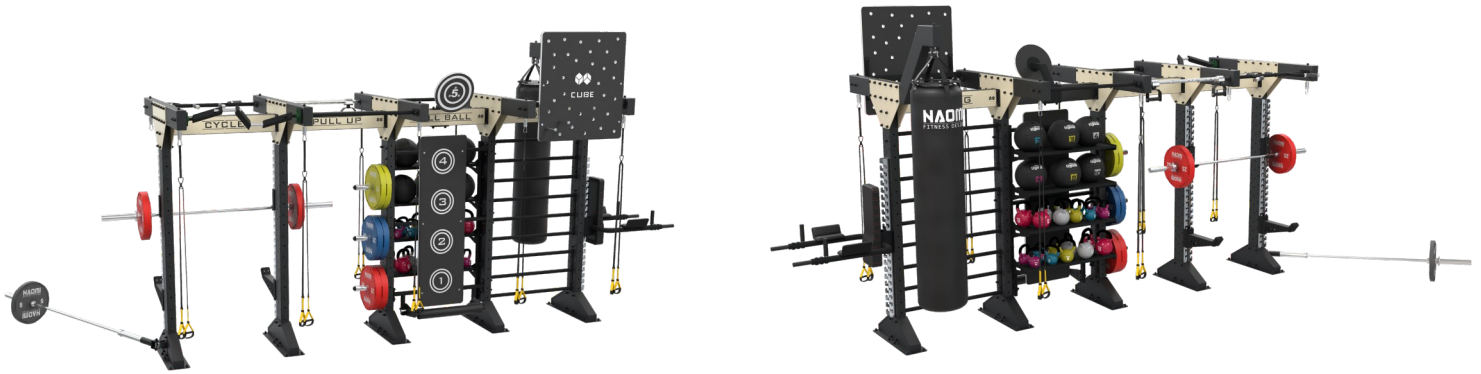

*An expanded model providing maximum functionality and space for multiple users simultaneously.*

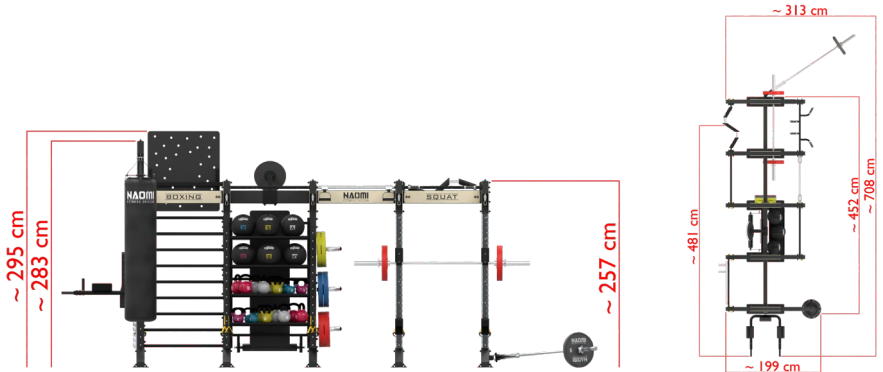

**Backyard Series – Backyard 5**   30 m<sup>2</sup> 👤 13 users



*The largest and most versatile version in the series, designed for intensive use in professional fitness facilities*



# D-Line Series - Outdoor – Robust and Modular Solutions for Advanced Training

The D-Line series consists of premium-class training cages created for the most demanding users. They feature reinforced construction, a modular expansion system, and resistance to intensive use. These cages are ideal for premium gyms, sports centers, and training studios requiring top-level durability.

The D-Line is also a larger version of the Cube solution, designed for various ladder and functional training configurations. With increased spacing between sides, the structure is perfect for obstacle course training (OCR), allowing for the installation of accessories such as different-shaped grips, monkey bars, and large pegboards. This design supports comprehensive grip strength training and agility development, making it ideal for functional and high-intensity interval training (HIIT) programs.

- ✓ Cost-effective solution – Optimized costs while maintaining full functionality.
- ✓ Space maximization – Training stations positioned around a single row of posts.
- ✓ Versatility – Suitable for both outdoor and indoor use.
- ✓ Flexibility and modularity – Customizable design with various grips, bars, and accessories.
- ✓ User capacity adjustment – Five variants to match the needs of your gym.

## D-Line Series – D200   33 m<sup>2</sup> ● 11 users



The basic model in the D-Line series, providing solid stations for strength and functional training. A great choice for professional training studios and smaller fitness clubs.

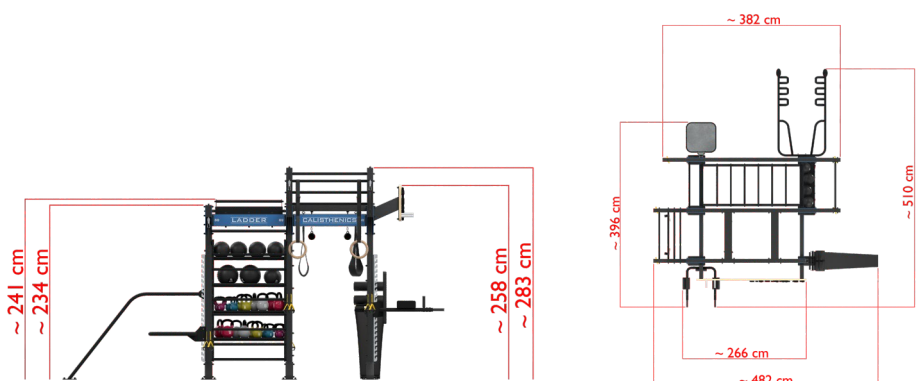

**D-Line Series – D300**   45 m<sup>2</sup> ● 14 users

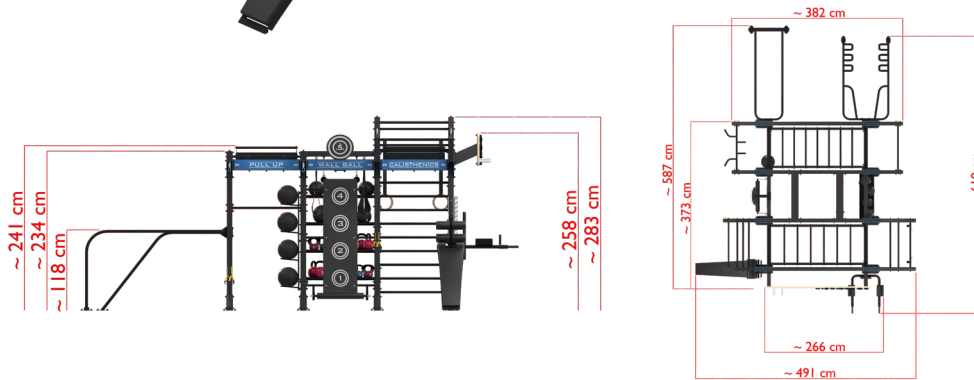

*A larger structure equipped with additional pull-up bars, grips, and accessory mounting systems, offering greater exercise versatility.*

**D-Line Series – D400**   52 m<sup>2</sup> ● 18 users

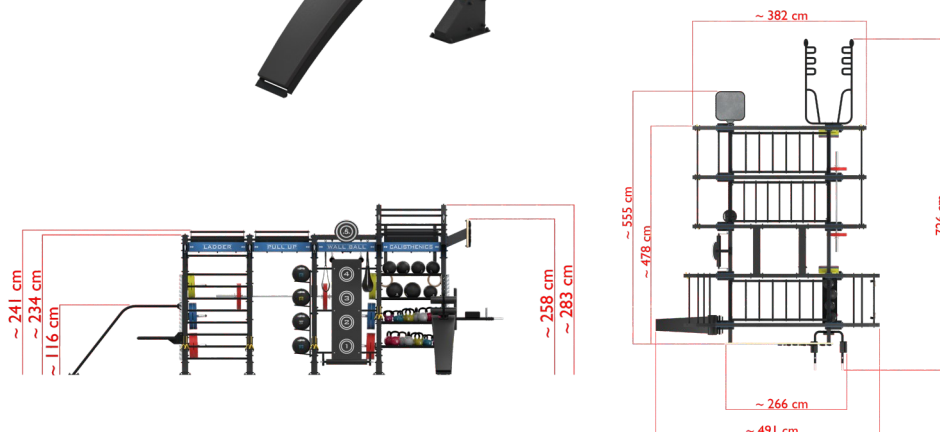
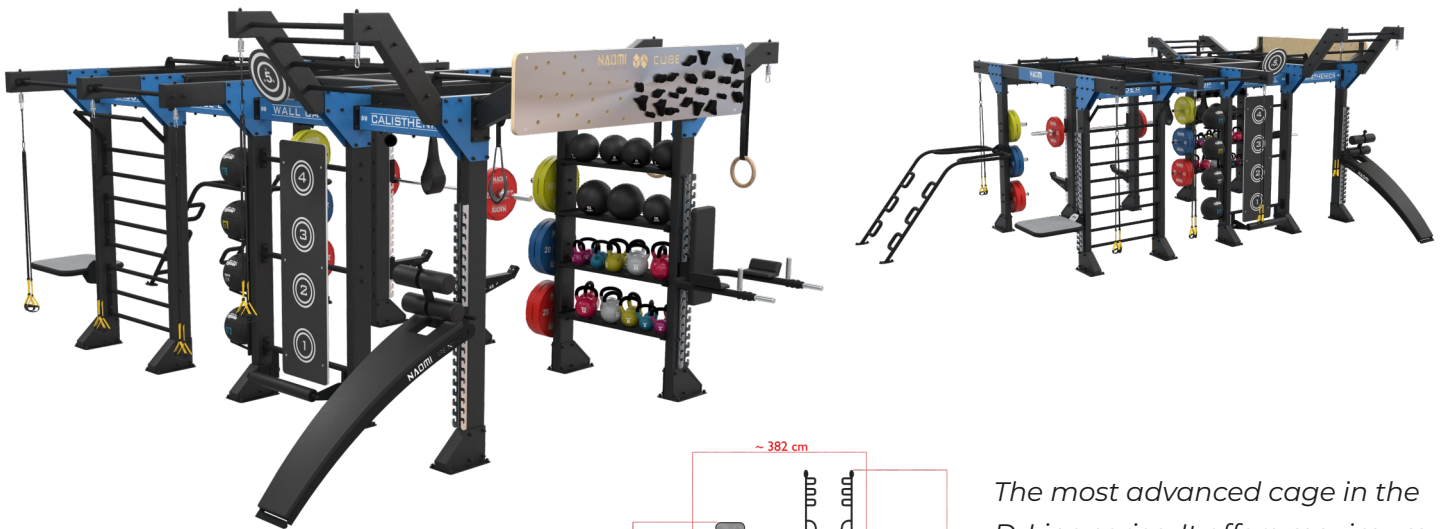

*The most advanced cage in the D-Line series. It offers maximum space and numerous configuration options, making it suitable for intensive use by multiple users simultaneously. Designed for gyms that value durability and flexibility in training zone arrangement.*

## Chameleon Series

---

*The Chameleon Series is an innovative line of functional training rigs that merges flexibility, smart space optimization, and scalable design. Created for fitness clubs seeking more than just equipment, Chameleon is a modular solution engineered to deliver maximum training variety with a minimal footprint.*

*By using upright columns of varying sizes and ends, Chameleon allows for the construction of larger training structures without significantly increasing floor space. Its intelligent architecture makes it a perfect match for CrossFit-style rigs, HIIT zones, and functional training areas where every square meter counts.*

*Though it doesn't support every NAOMI module, its cleverly engineered frame allows you to connect multiple workout zones into one compact structure. This makes it ideal for clubs that want to maximize member throughput without compromising layout or aesthetics.*

### **Key Benefits:**

**Scalability** – Build large, multi-user setups while maintaining a compact footprint

**Space Optimization** – Perfect for gyms looking to increase training stations without expanding square footage

**Designed for CrossFit & Functional Training** – Built for strength and endurance-based formats

**Modular Integration** – Combine strength, cardio, and accessory zones in one frame

**Durability** – Built in Poland using premium-grade materials for long-lasting use

**Customization** – Choose any color from the RAL palette and tailor your cage layout to fit your branding and training style

**Chameleon Series – Silver** 30 m<sup>2</sup> 👤 9 users

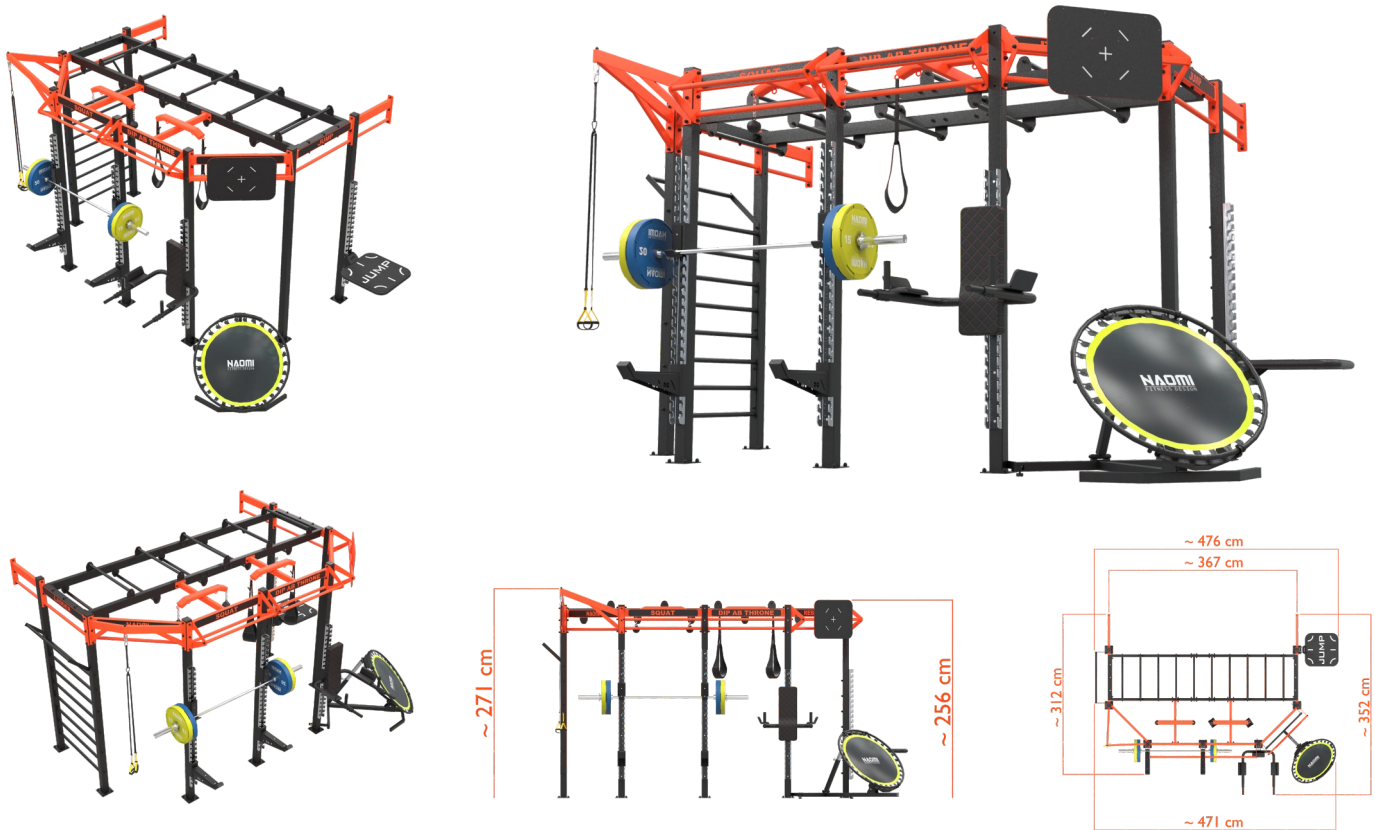

**Chameleon Series – Gold** 49 m<sup>2</sup> 👤 13 users

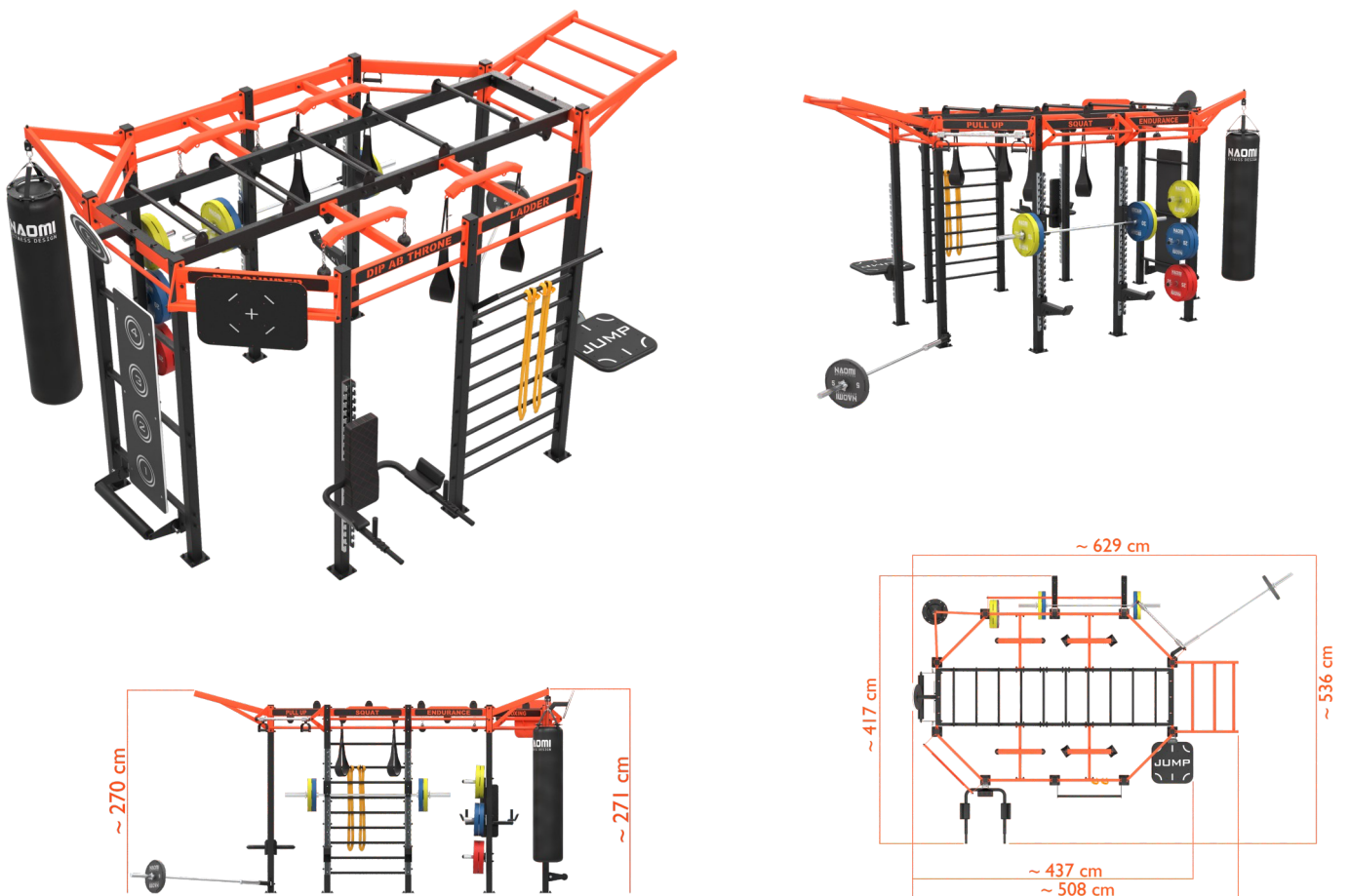

# Chameleon Series – Excellerate

44 m<sup>2</sup> 15 users

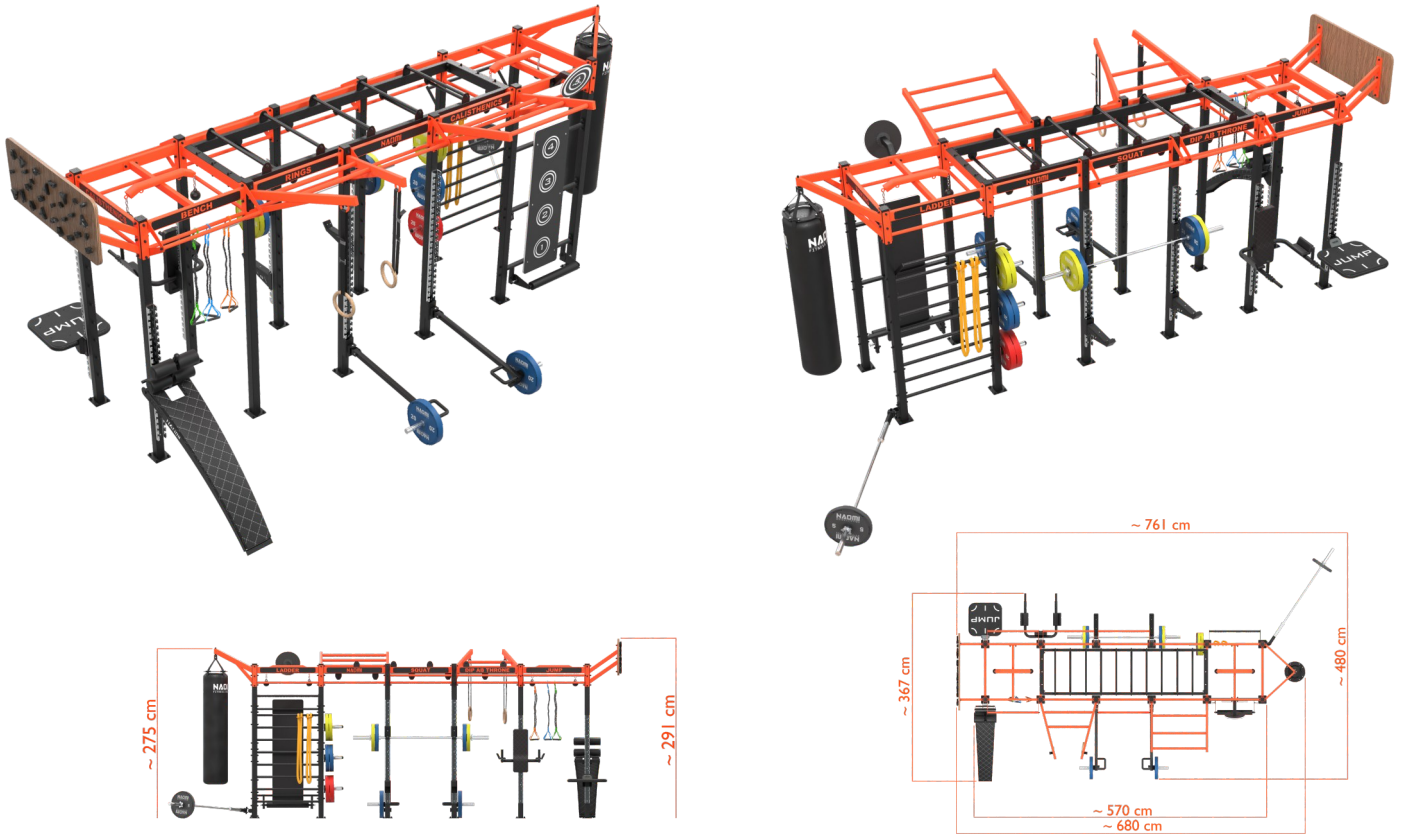

# Chameleon Series – XXL

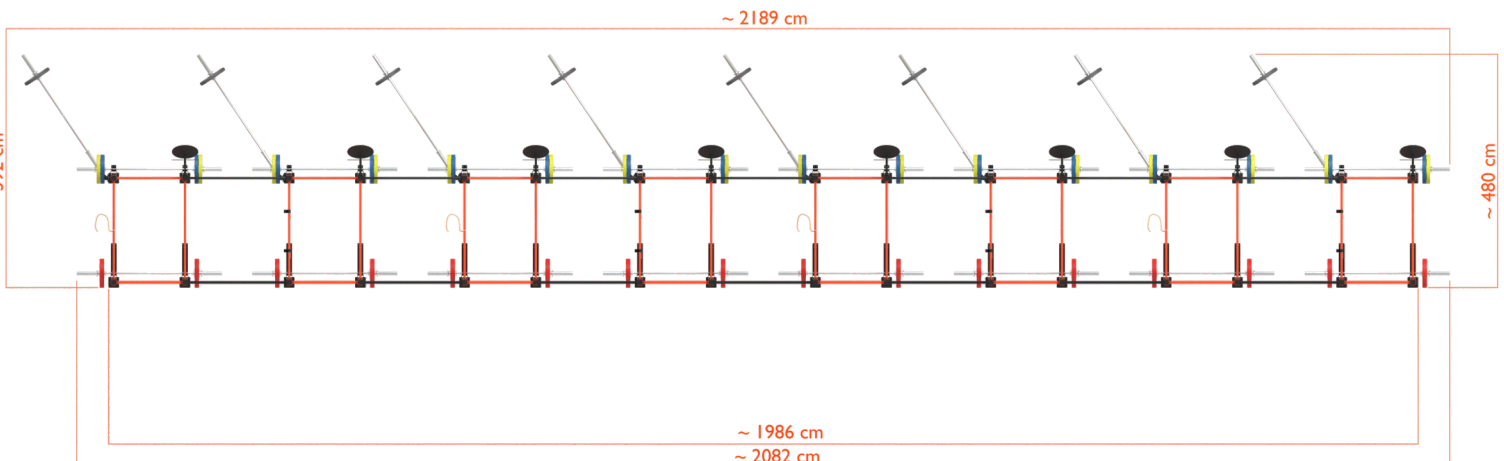
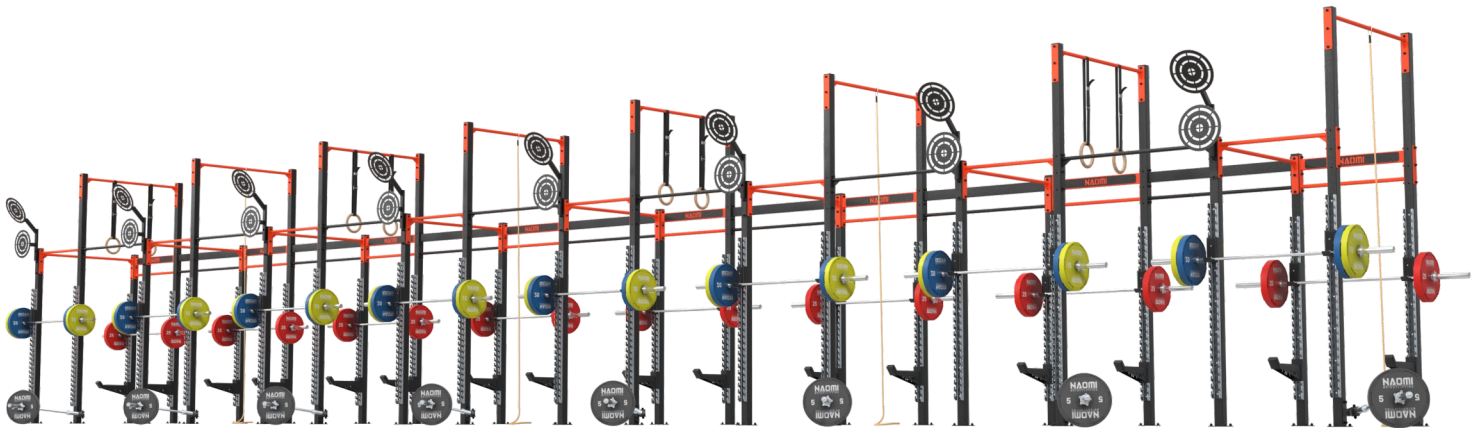

# Naomi Boxing Solutions

---

*Naomi Boxing Solutions are designed for modern fitness clubs that value space-efficiency, training diversity, and aesthetic integration. Our boxing line combines high-performance engineering with modular flexibility, offering a range of systems that seamlessly fit into any environment—from boutique studios to large-scale functional zones.*

*The collection includes wall-mounted boxing arms that save floor space while ensuring rock-solid support, and ceiling-mounted frames for clubs looking to free up wall areas without sacrificing performance. Our suspension bridges provide a dynamic solution for group training, allowing boxing bags, TRX systems, and other hanging tools to coexist in a shared space.*

*With rail systems, users can easily slide boxing bags along a track to reconfigure the space in seconds—no tools, no downtime. What truly sets NAOMI apart is our ability to combine boxing infrastructure with functional training modules, creating hybrid rigs that support a full spectrum of workouts—from power punches to kettlebell swings and plyometric drills. Every element is manufactured in Poland, compliant with EU quality standards, and available with full customization - including RAL color options, logo branding, and tailored station layouts.*

*Whether you're optimizing a tight corner or building a flagship boxing zone, NAOMI's boxing solutions deliver unmatched durability, innovation, and visual impact.*



# Wall Mounted Boxing

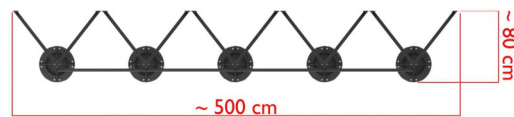
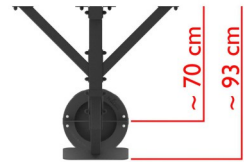
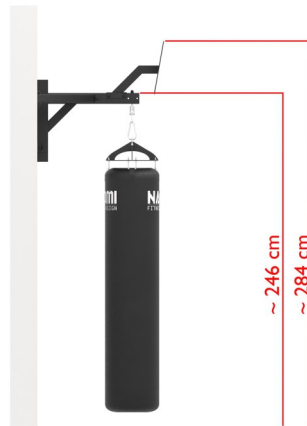
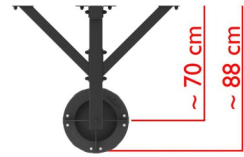
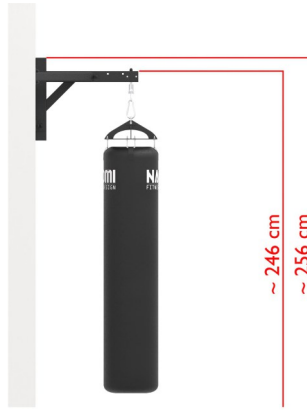

# Multibay Boxing

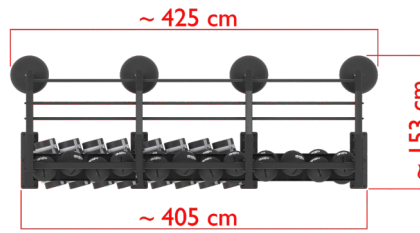
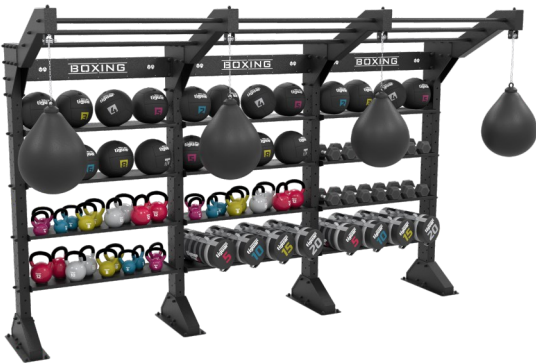
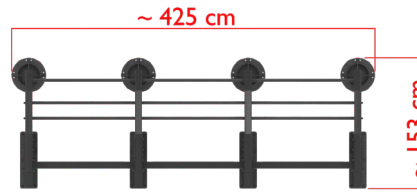

# Basic Boxing Bridge

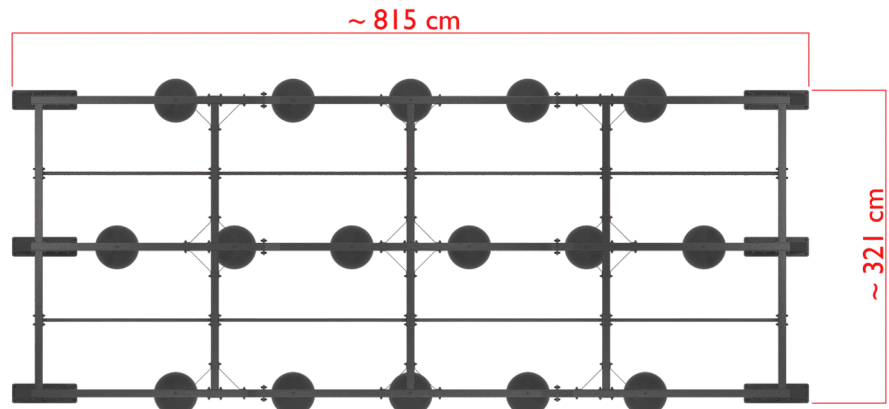
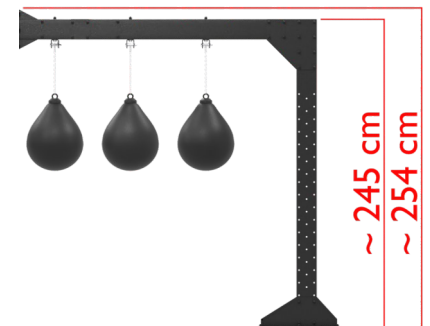
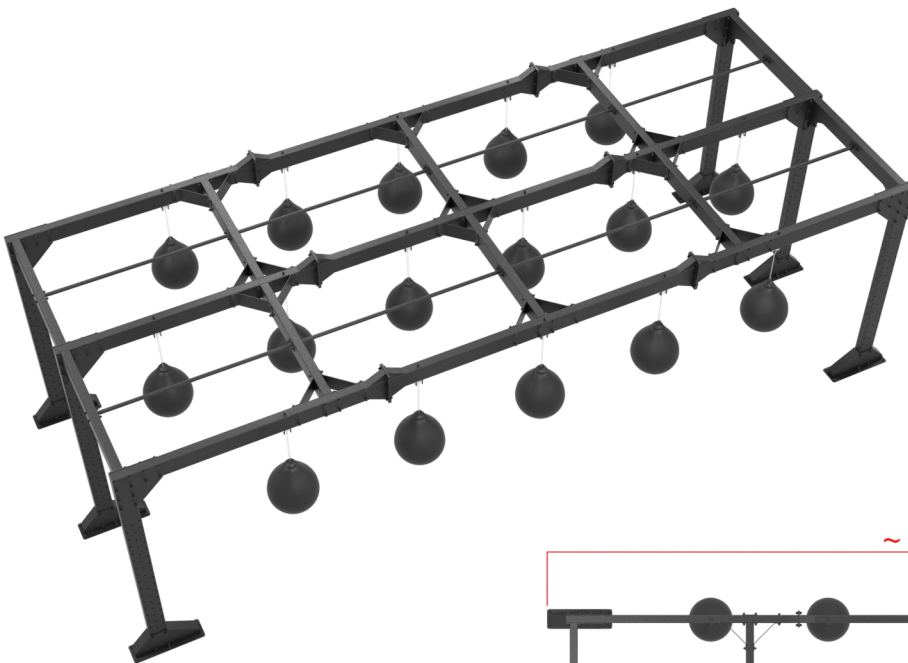

# Suspension Bridge Boxing

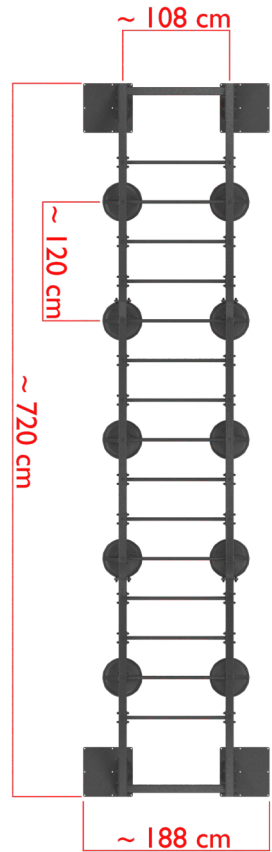
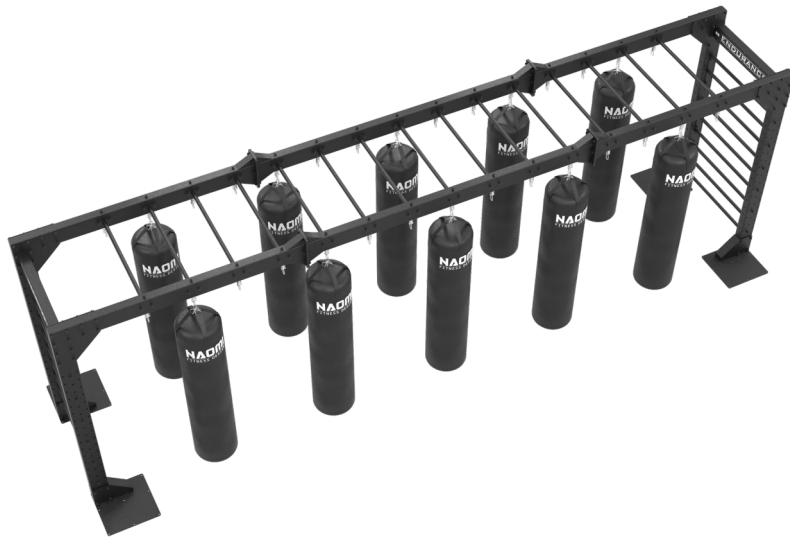

# Suspension Boxing Bridge with rail system

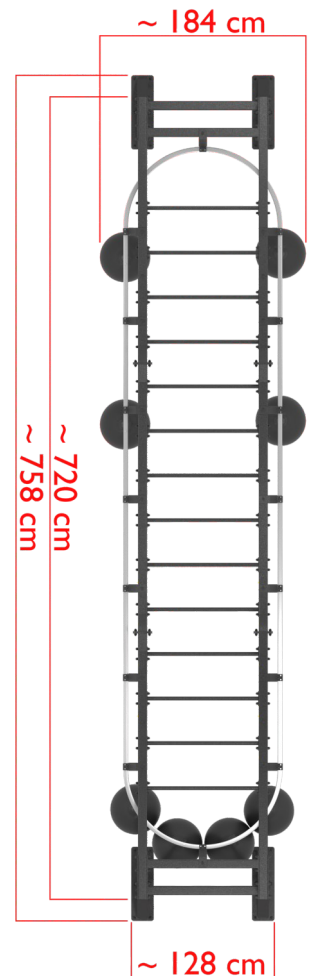
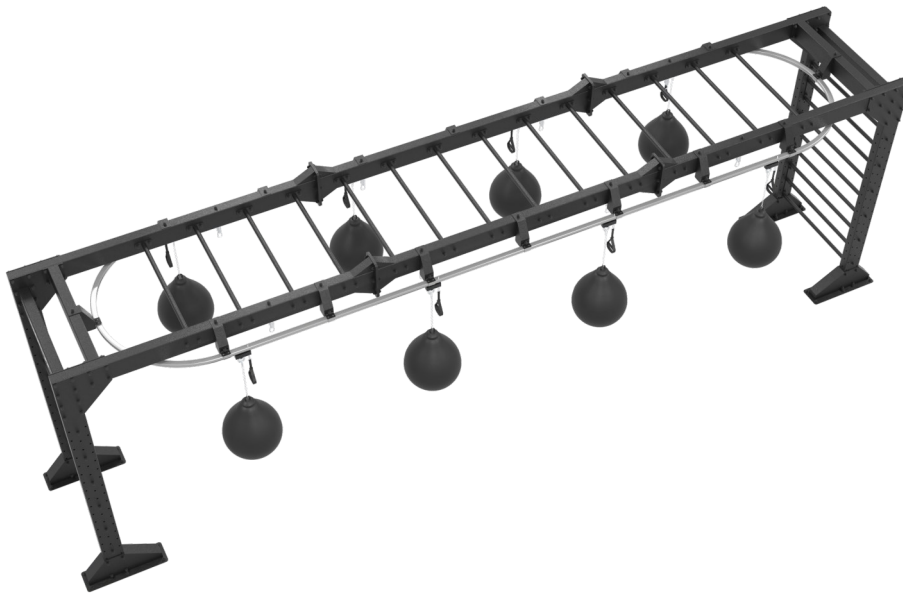

# Functional Boxing with Rail System

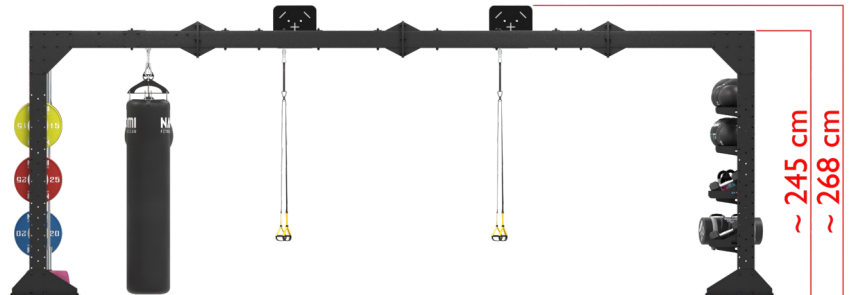
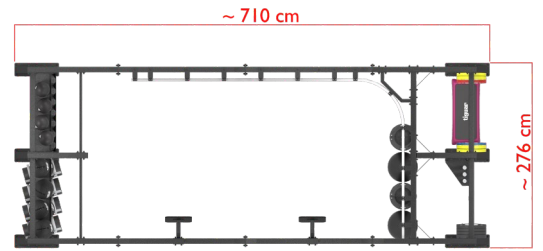
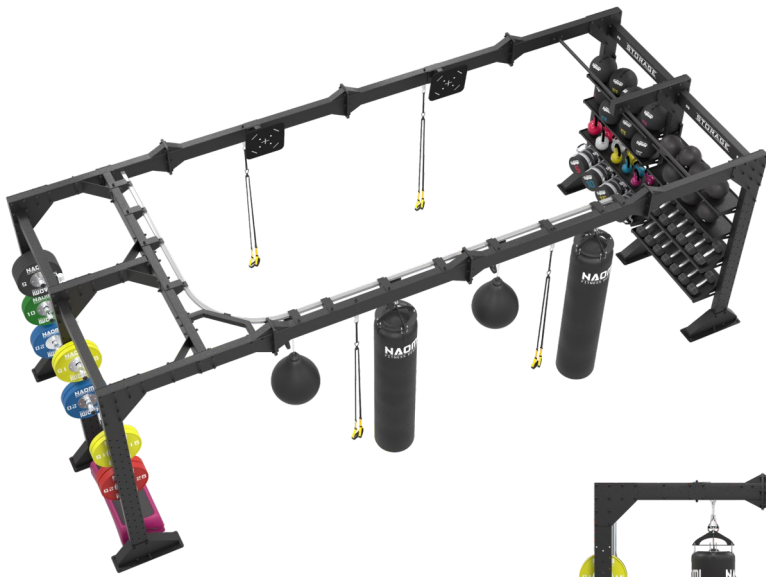

# Multibay boxing with rail system

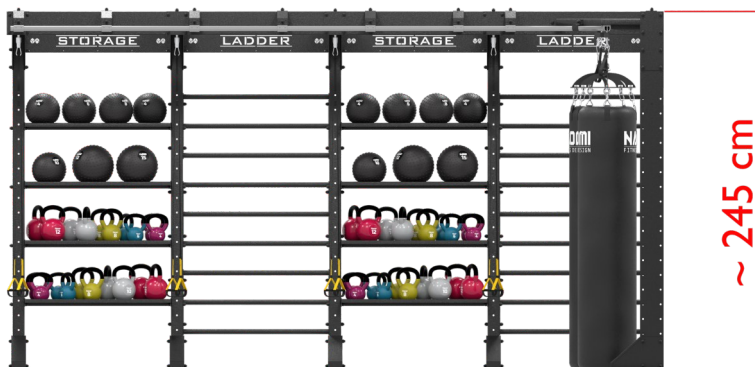
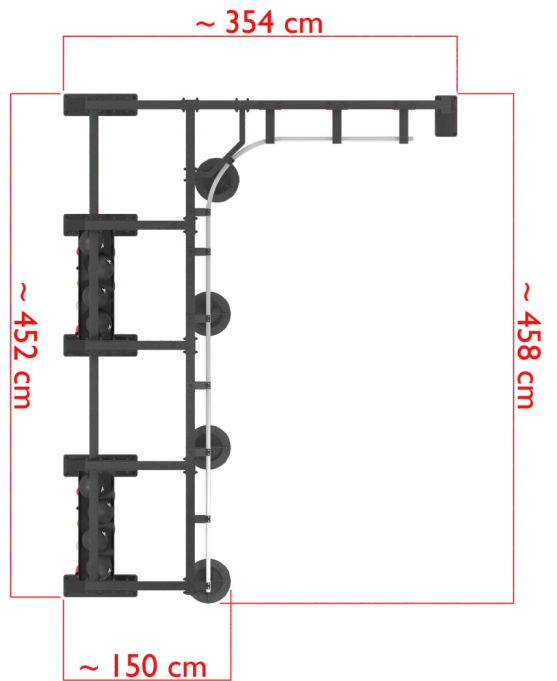

# Single Boxing bridge with rail system

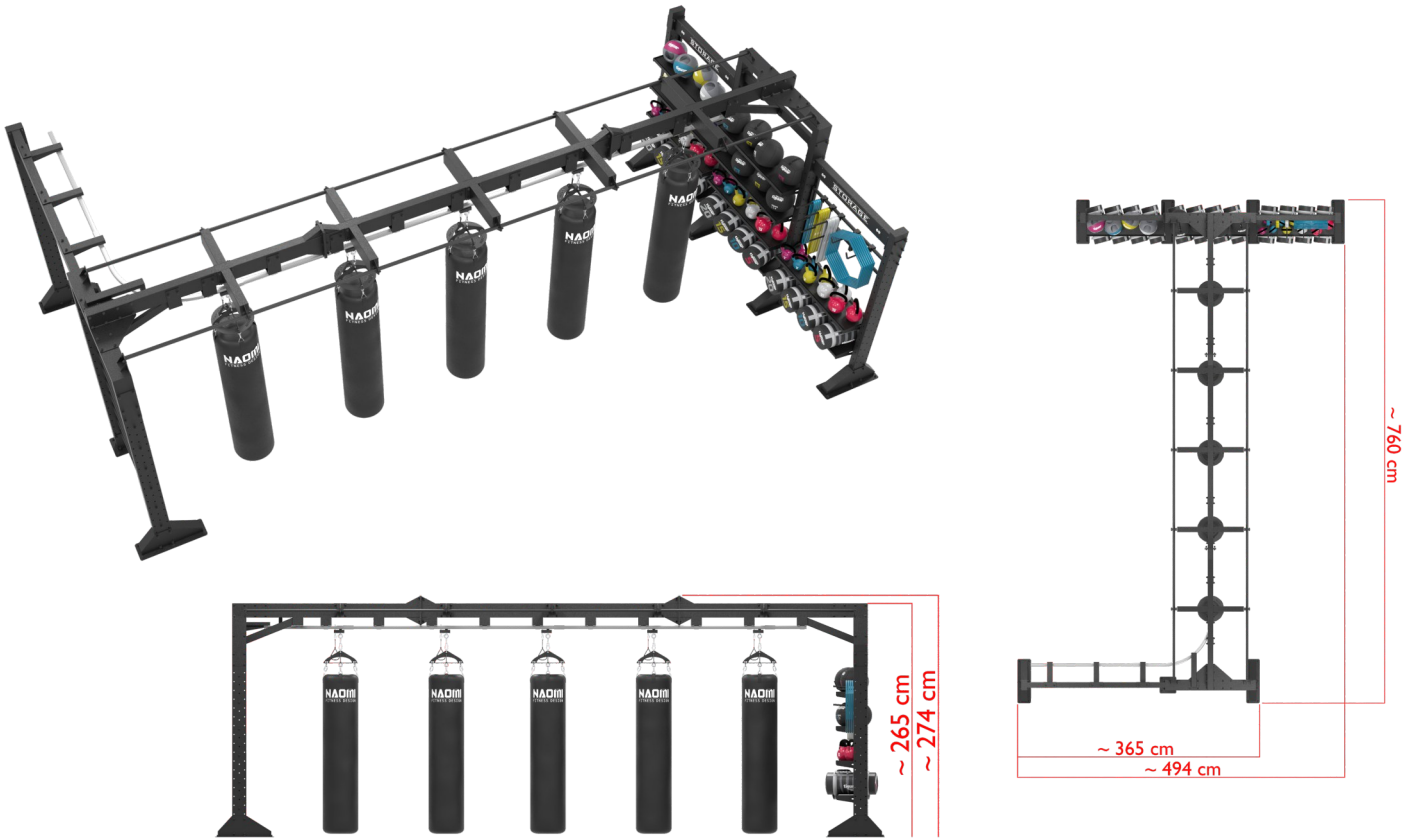

# Combo bridge

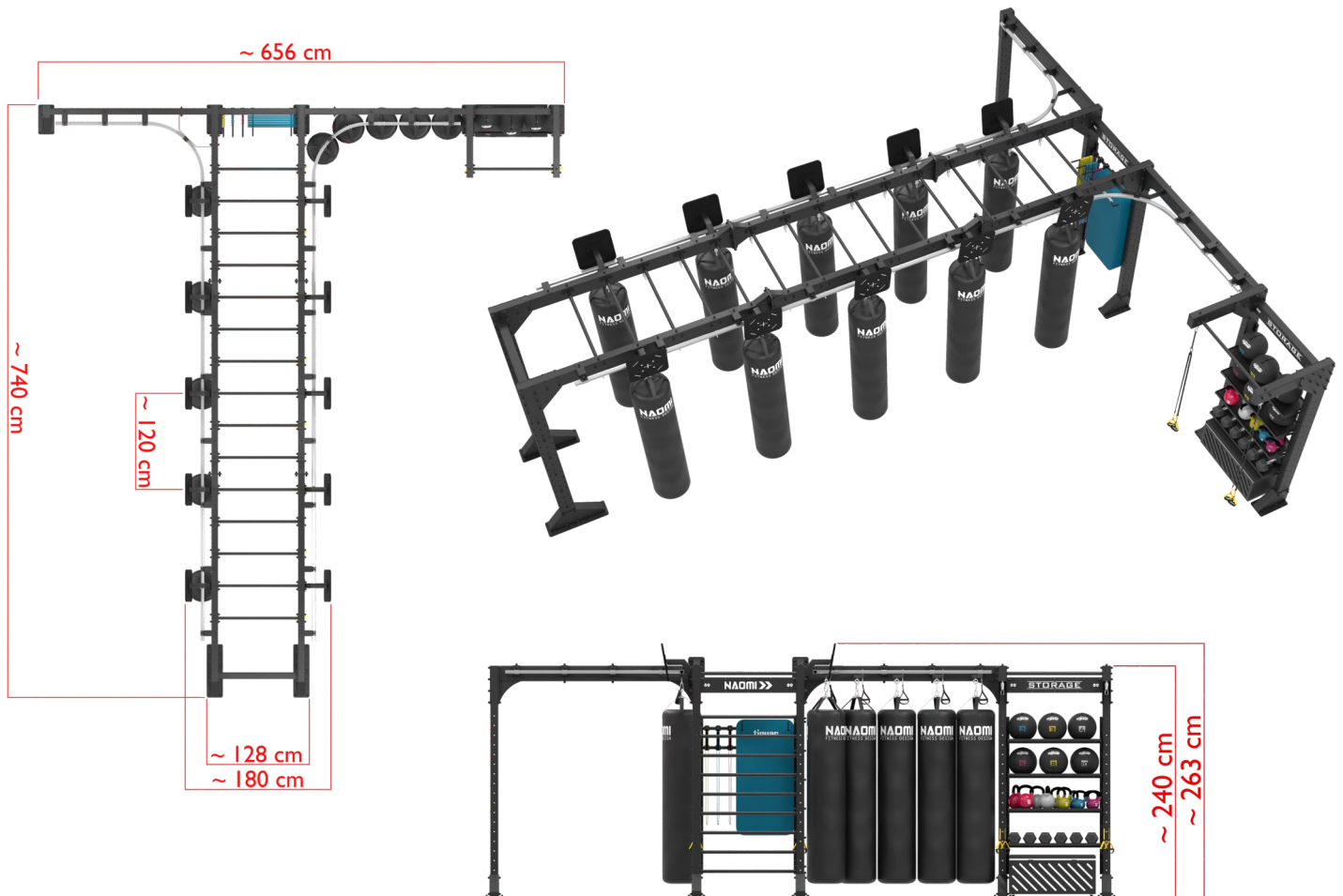

# Ceiling Mounted Suspension with Rail System

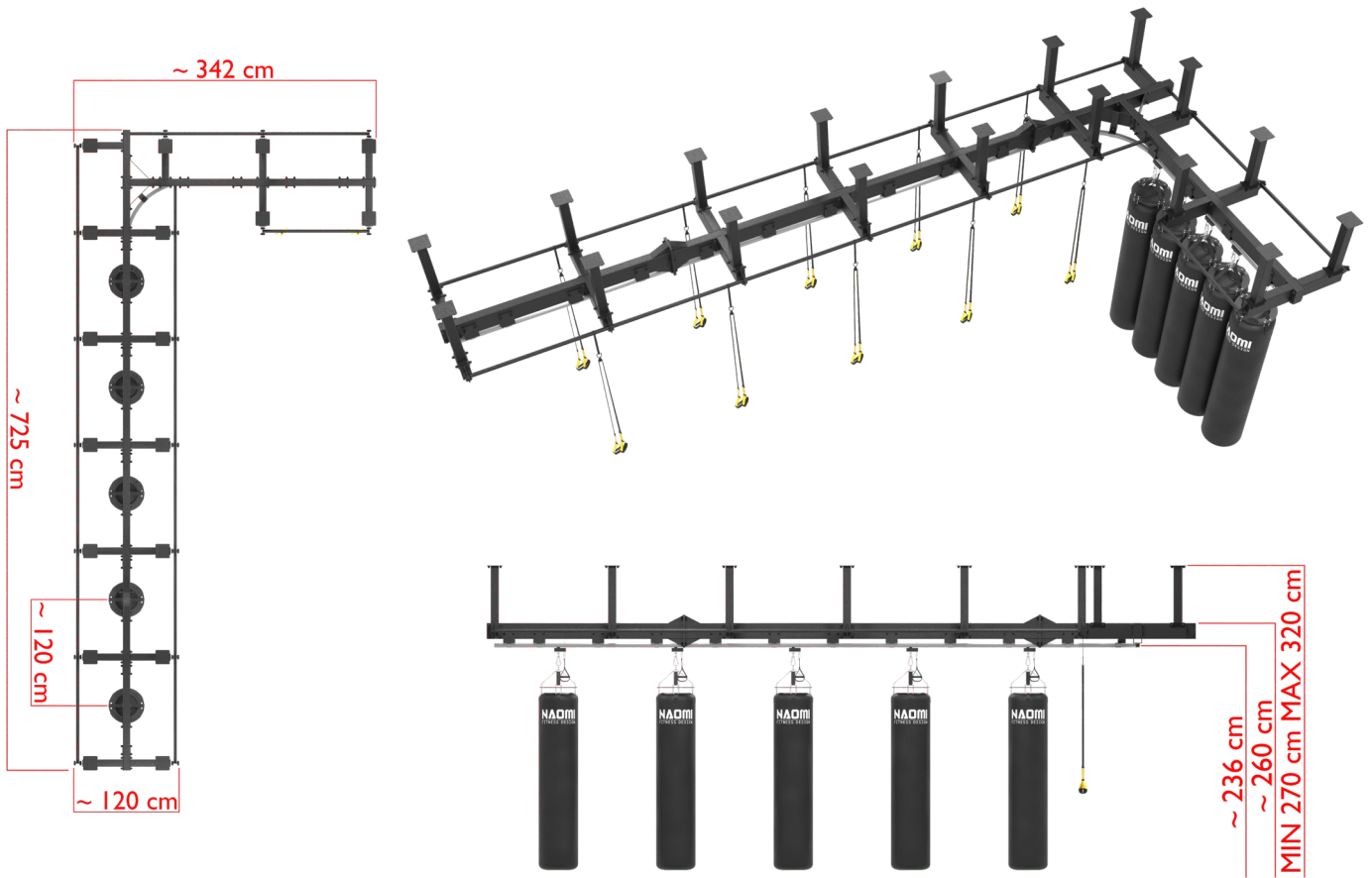

Ceiling mounted rail system

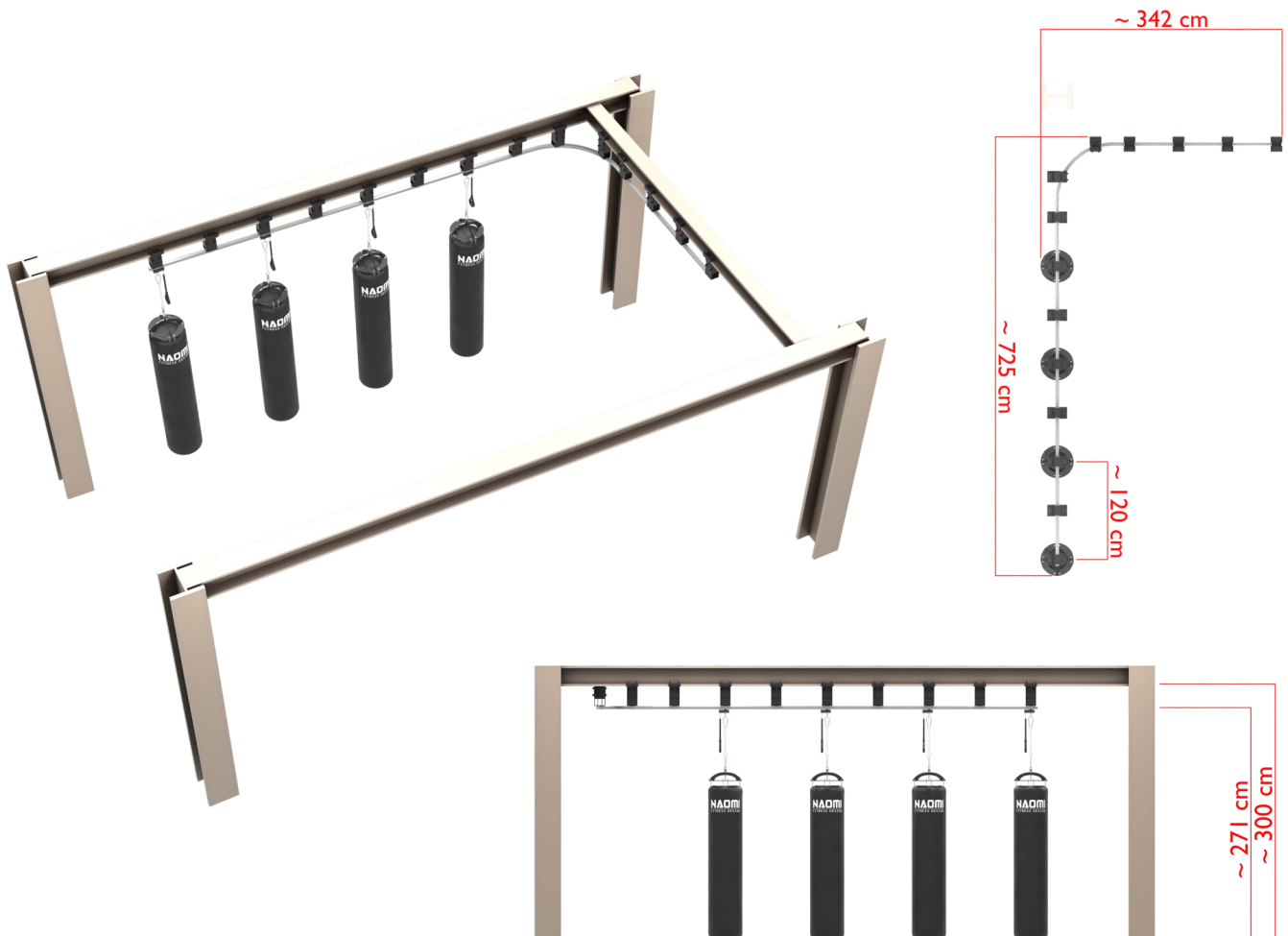

# Backyard Boxing 360

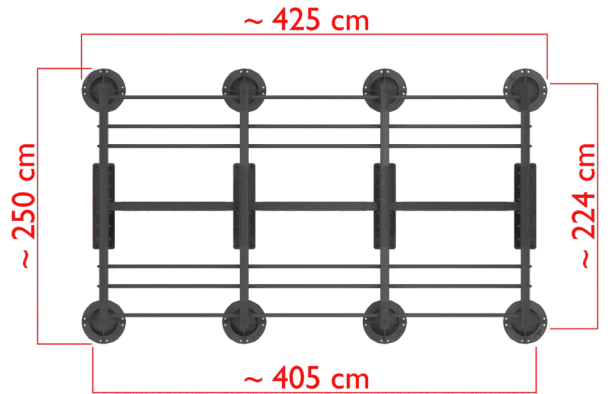
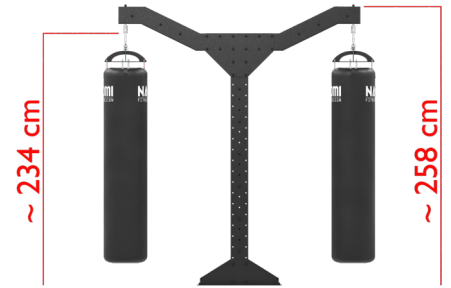

# XXL Boxing Solutions

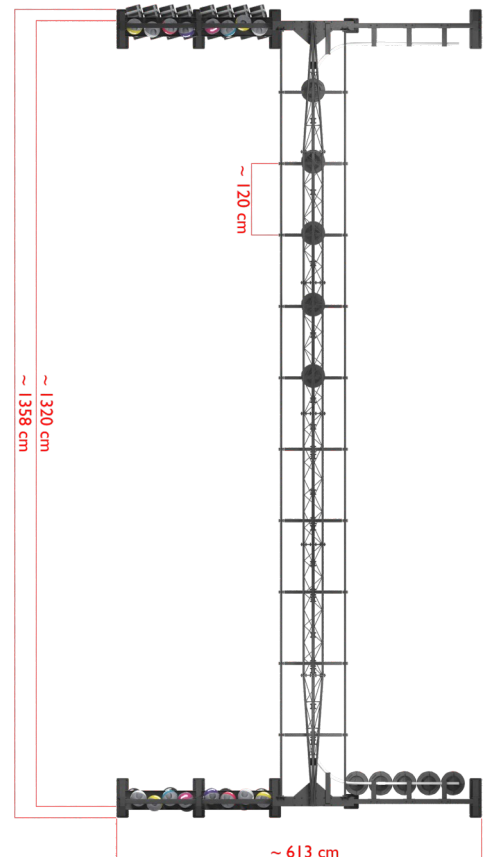
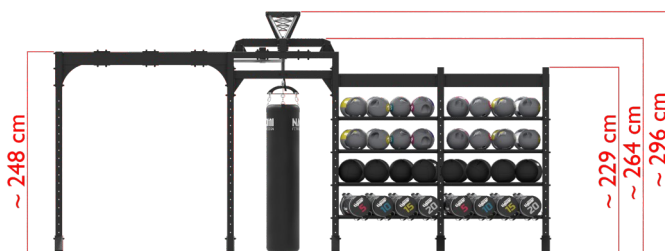
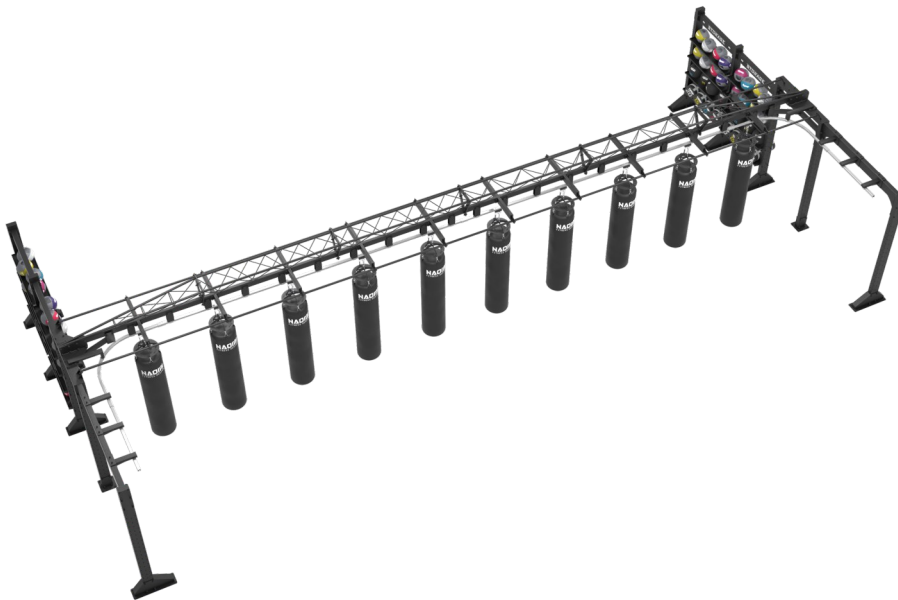

# Naomi Strength

## MINI RACK



## HALF RACK v3

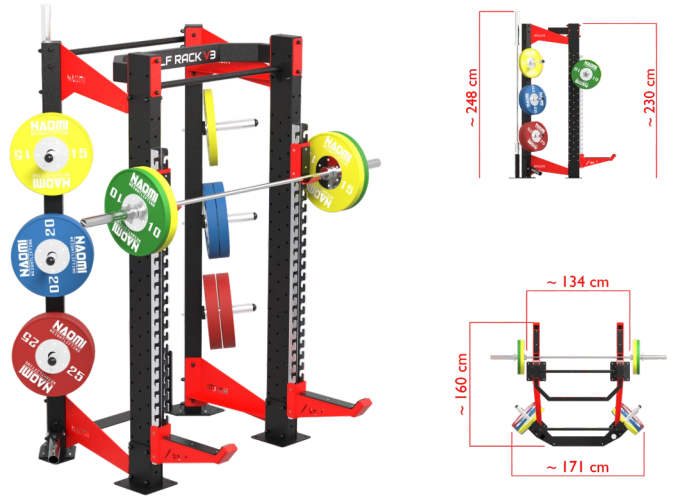

## CABLE CROSS

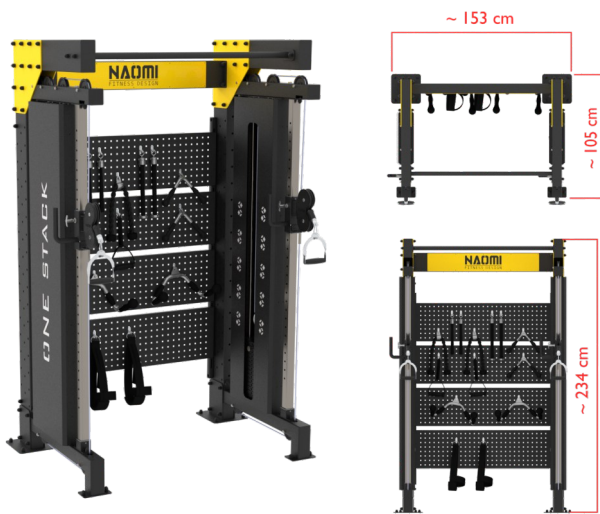

## FUSION RACK

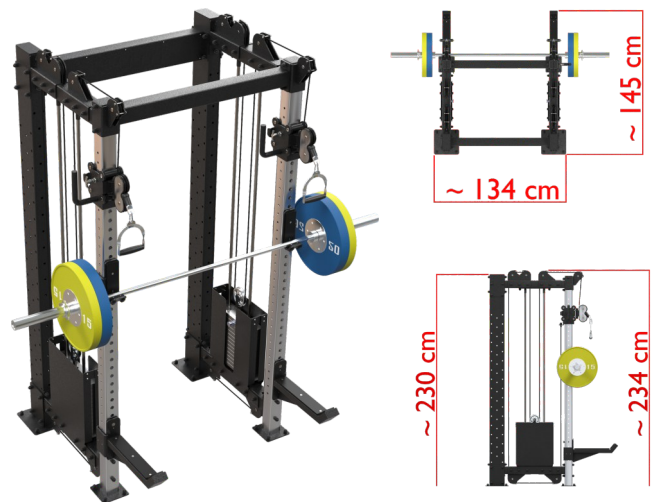

## CABLE CROSS

## FUSION RACK



available  
**THICKNESS**  
30cm / 50mm

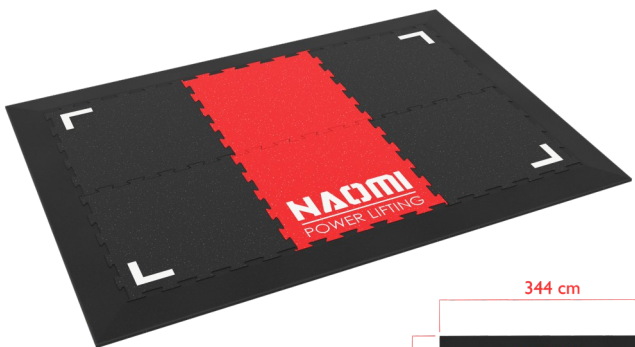
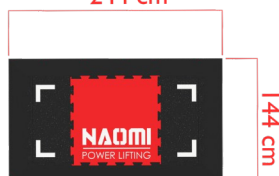

available  
**THICKNESS**  
30cm / 50mm



# 10X TRAINING

## **THE CONCEPT EXPLAINED**

*10XTraining is a NAOMI FITNESS DESIGN signature team training program that blends functional strength-type exercises with cardio, core, or mobility non-equipment exercises. This variety ensures that workouts remain engaging and effective, preventing plateaus and fostering continuous improvement.*

*Each 30-minute session is structured in a circuit-training, time-based format, supported by technology to provide visual guidance for exercises, making 10XTraining a straightforward, engaging fitness solution. This program is designed for those looking to break free from workout monotony, achieve measurable fitness goals, and enjoy a simplified training experience.*

*Its innovative approach, which includes a vast library of exercises, targets all facets of fitness for balanced results, catering to a diverse range of fitness levels and goals.*

# 10XTR<sup>TRAINING</sup>

## XW5



## DETAILS

system for 10 people

Signature team training concept

Just 30minutes: cardio, core, mobility workouts

40sqm flooring - 27sqm workout zone

8 x 5 meters ( + 24cm each side for slope )

38

# 10X TRAINING

## XW7

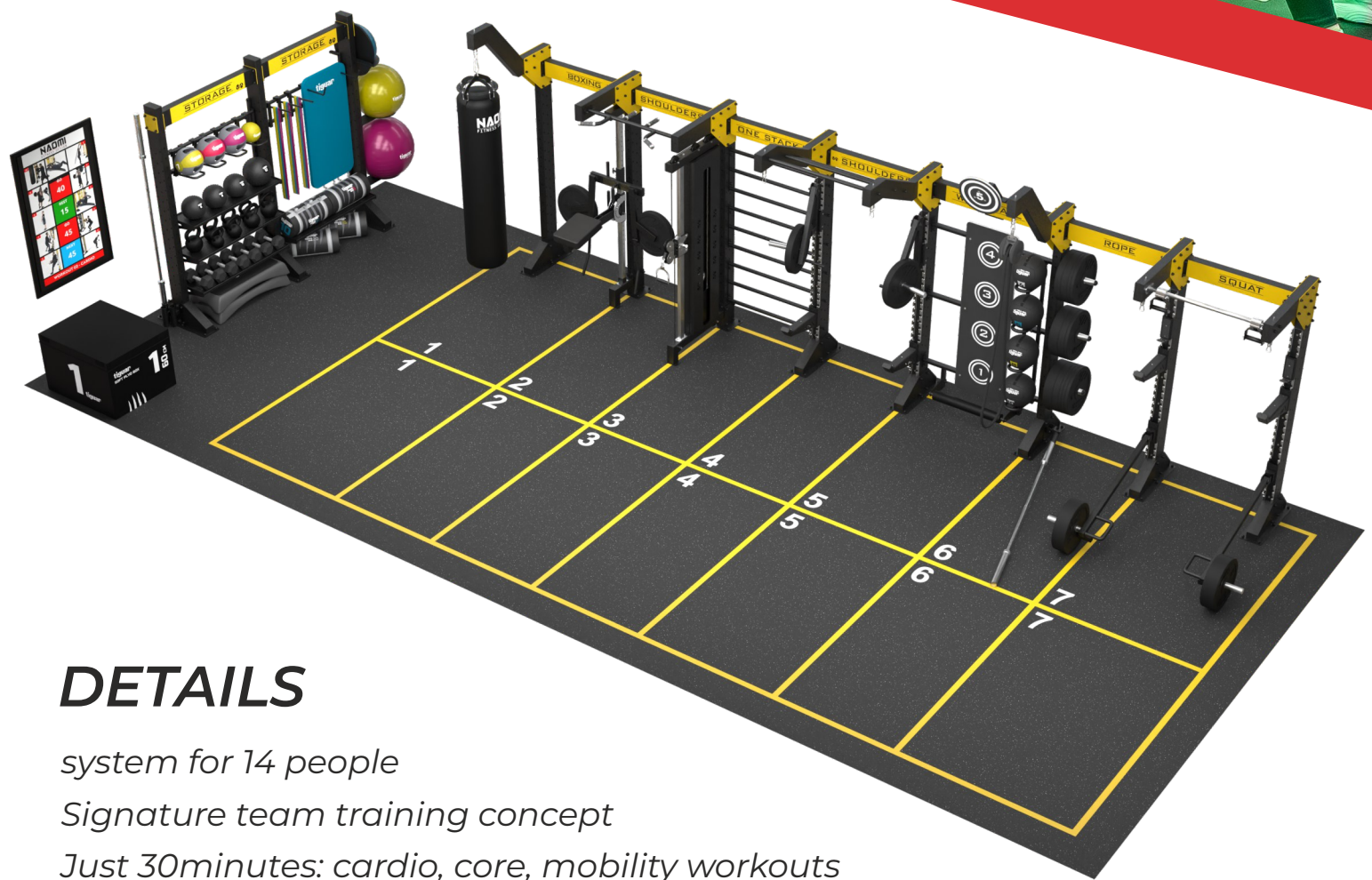

## DETAILS

system for 14 people

Signature team training concept

Just 30minutes: cardio, core, mobility workouts

55sqm flooring - 38sqm workout zone

11 x 5 metters ( + 24cm each side for slope )



## **BENEFITS FOR CLUB OPERATORS**

*Retention strategy: Foster a strong community feeling with 10XTraining, offering an inspiring and empowering experience that keeps members engaged and committed to their fitness journey.*

*Club members' loyalty: Benefit from a structured program that captivates members, encourages regular participation, and deepens their loyalty to your club.*

*Attracting new members: With an excellent onboarding solution, 10XTraining is designed to welcome individuals at all fitness levels, ensuring everyone finds their place and pace.*

*Technology integration: Implement a "non-thinking required" solution. 10XTraining's technology allows for a seamless plug-and-play setup, simplifying operations and enhancing the workout experience.*

*Easy scaling: Whether expanding your offerings at one location or rolling out across multiple locations, 10XTraining's simple implementation ensures consistent quality and member experience everywhere.*

*Competitive edge: Stand out with a Unique Selling Proposition (USP) by offering innovative training concepts that differentiate your club from the competition. This will make your facility the go-to destination for those seeking a unique home-away-from-home experience.*

# 10X TRAINING XW8

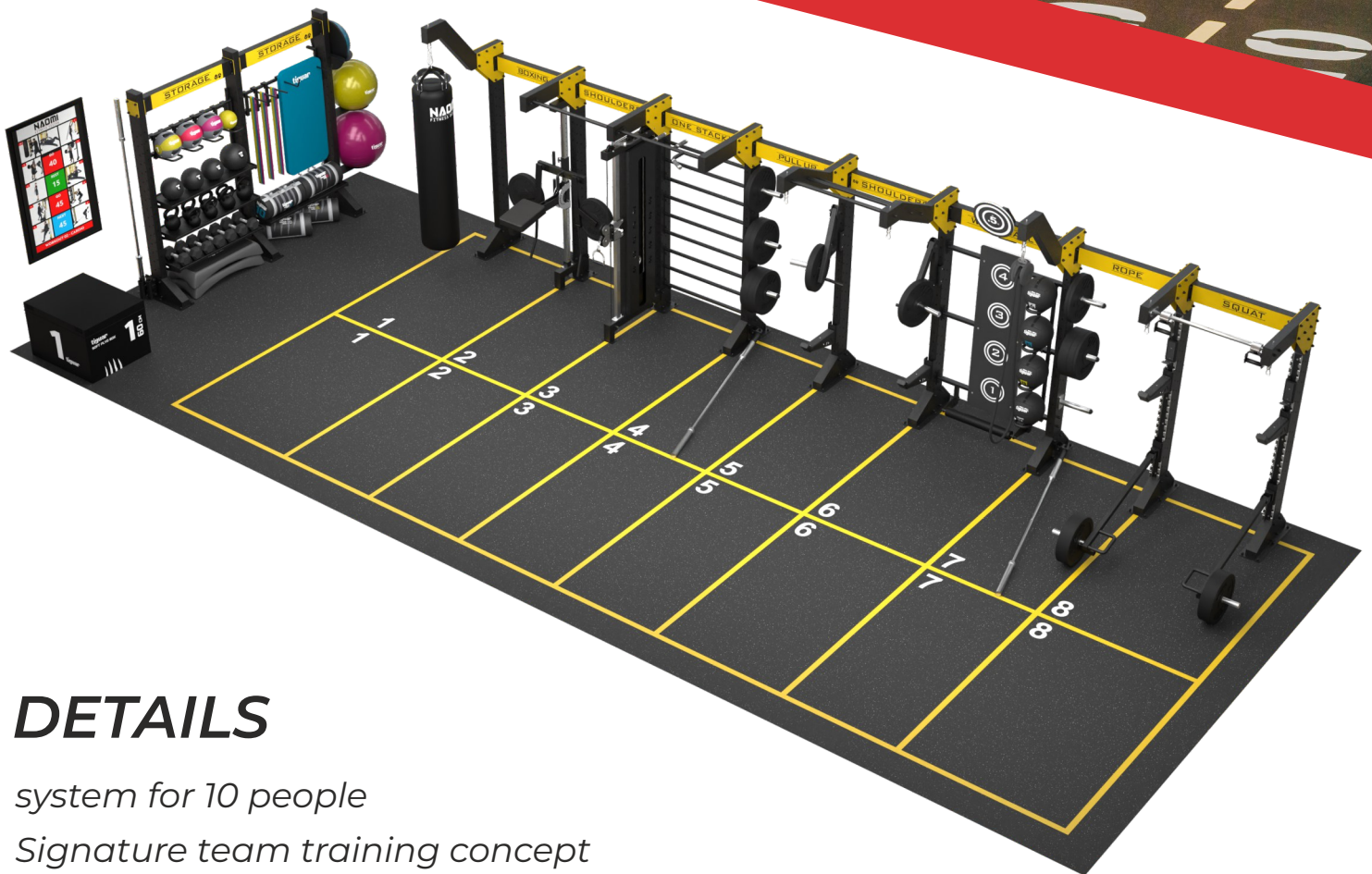

## DETAILS

*system for 10 people*

*Signature team training concept*

*Just 30minutes: cardio, core, mobility workouts*

*60sqm flooring - 43sqm workout zone*

*12 x 5 meters ( + 24cm each side for slope )*



#### **CLUB MEMBERS BENEFITS:**

- *Fun workouts: Engage in diverse and exhilarating workouts that spark motivation with every session. 10XTraining ensures that fitness is never monotonous, always keeping you on your toes with new challenges and routines.*
- *All-in-one fitness: Experience the perfect blend of strength, cardio, and flexibility training in every session. 10XTraining's holistic approach means you can achieve all your fitness goals under one roof, with every workout designed to push your limits and enhance your capabilities.*
- *Tech-savvy: Embrace the ease of tech-guided exercises. With 10XTraining's innovative technology, every movement is clearly demonstrated, ensuring you can focus on perfecting your form and maximizing your workout without any guesswork.*
- *Personal touch: Benefit from the personalized support that matches your unique fitness journey. Whether you're a beginner or a seasoned athlete, 10XTraining coaches provide the tailored guidance and motivation you need to reach your personal best.*
- *Community spirit: Join a vibrant fitness family that supports and cheers for each other. 10XTraining fosters a strong sense of community by making workouts about fitness, belonging, and encouragement.*
- *Always Fresh: With 10XTraining, the fitness routine constantly evolves, ensuring you never hit a plateau. Fresh, creative workout programs are designed to keep you engaged and excited about what comes next, making every visit to the gym an adventure.*

# 10X TRAINING

## XW10

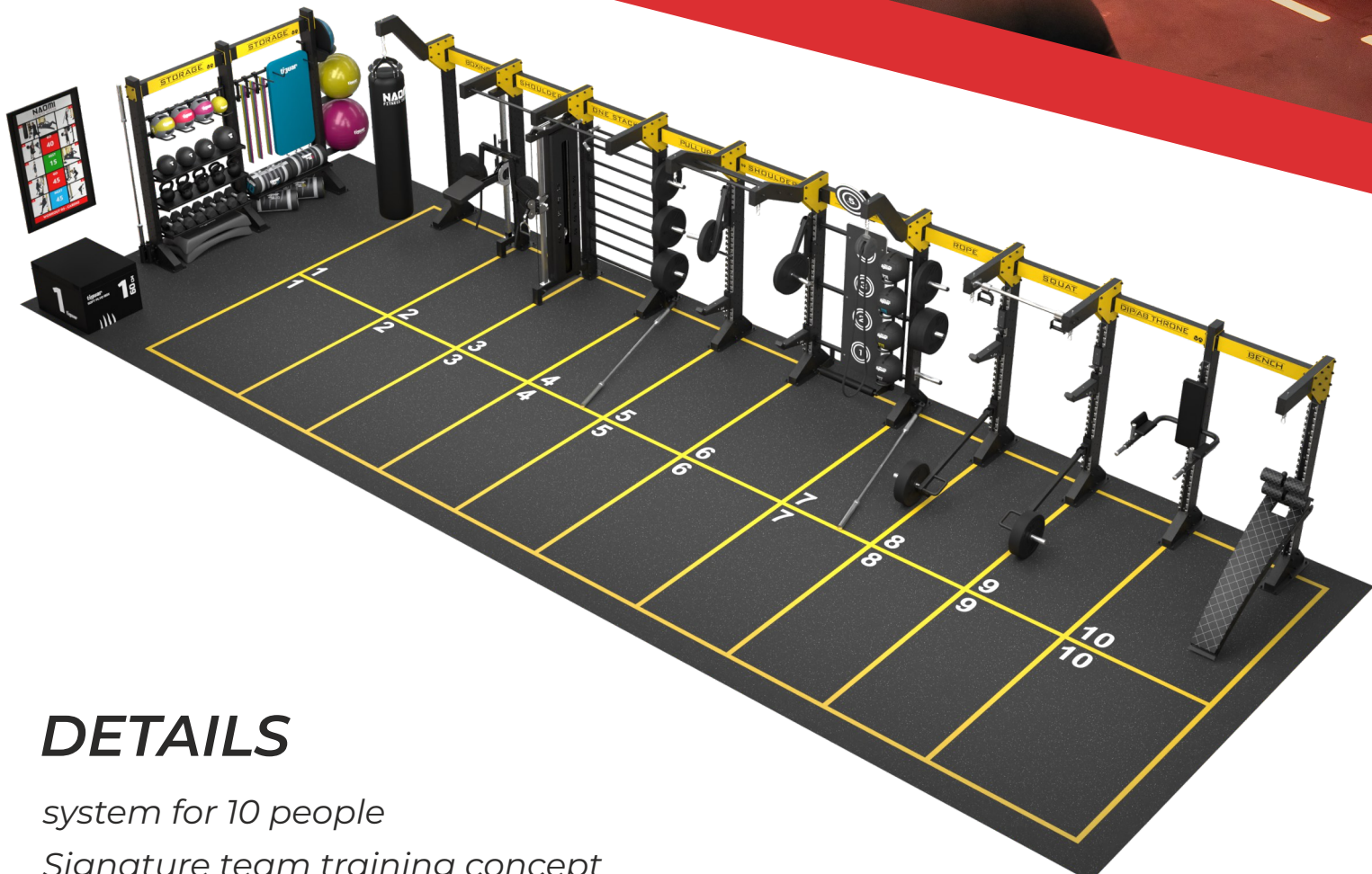

## DETAILS

system for 10 people

Signature team training concept

Just 30minutes: cardio, core, mobility workouts

70sqm flooring - 52sqm workout zone

14 x 5 meters ( + 24cm each side for slope )

# 10XTR<sup>TRAINING</sup> X200

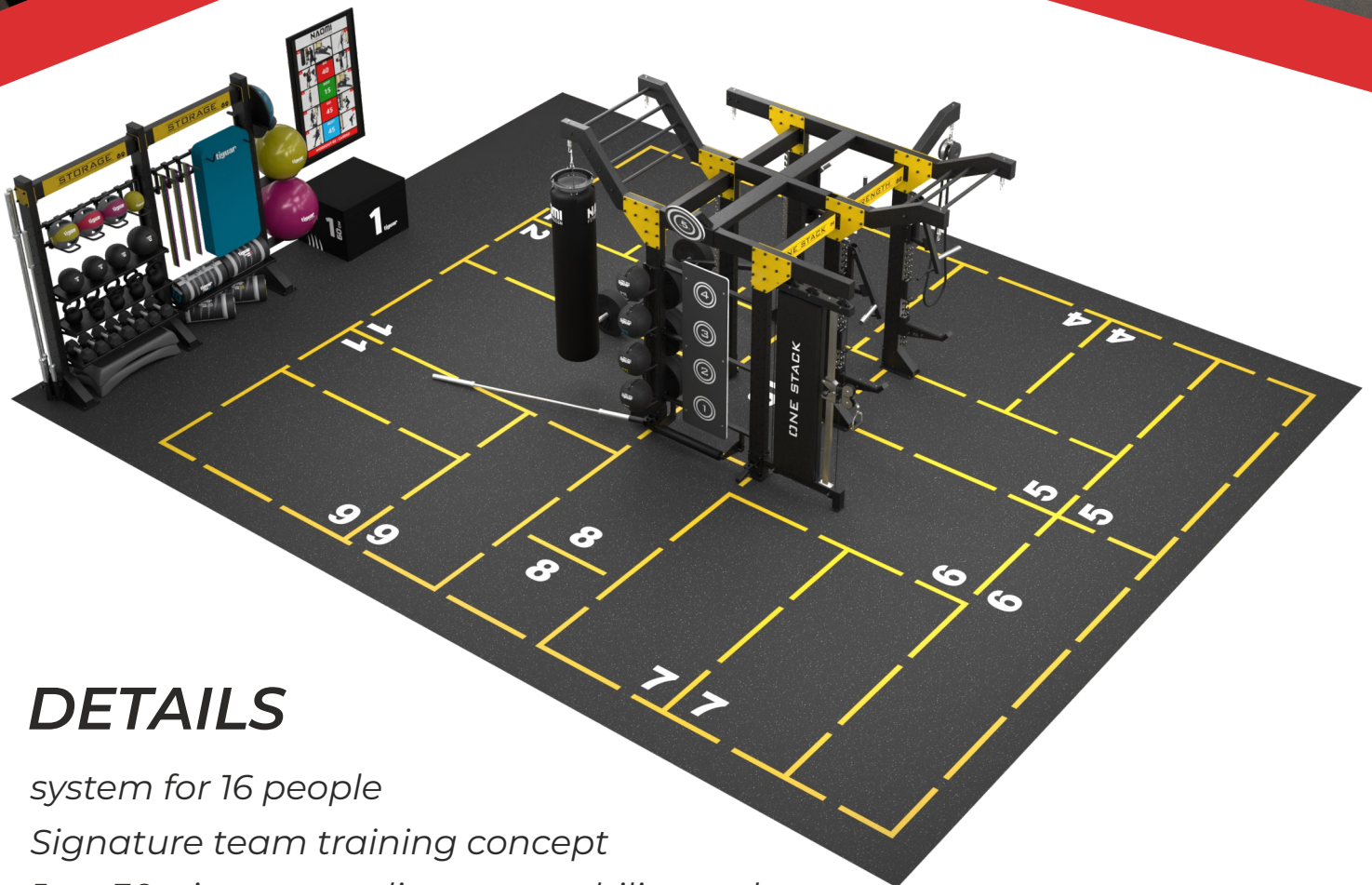

## DETAILS

*system for 16 people*

*Signature team training concept*

*Just 30minutes: cardio, core, mobility workouts*

*80sqm flooring - 58sqm workout zone*

*8 x 10 metters ( + 24cm each side for slope )*



## **PROFESSIONAL, SEAMLESS, AND PERSONALIZED SERVICE**

*The decision to integrate 10X Training into your club brings with it a professional, seamless, and personalized service aimed at ensuring the 10X Training solution perfectly complements your business model.*

*From the initial contact through to the full implementation and beyond, you'll receive expert guidance and support designed to make the installation as straightforward and beneficial as possible.*

*What you receive:*

- *NAOMI workout cage: The centerpiece of 10X Training signature workouts, designed to withstand high-intensity use and comply with EU standards, ensuring durability and quality.*
- *Numbered tile flooring: Clearly defined workout stations enhance the structure and flow of sessions, supporting the program's unique circuit-training format.*
- *Functional equipment accessory pack: A carefully selected range of accessories to fully equip your gym for the 10X Training program, catering to a wide array of workouts and fitness levels.*
- *Technology integration: Workouts displayed on a large TV monitor provide clear visual guides for participants, making for an accessible and engaging workout experience that requires no prior planning from coaches or members.*

# 10X TRAINING X300

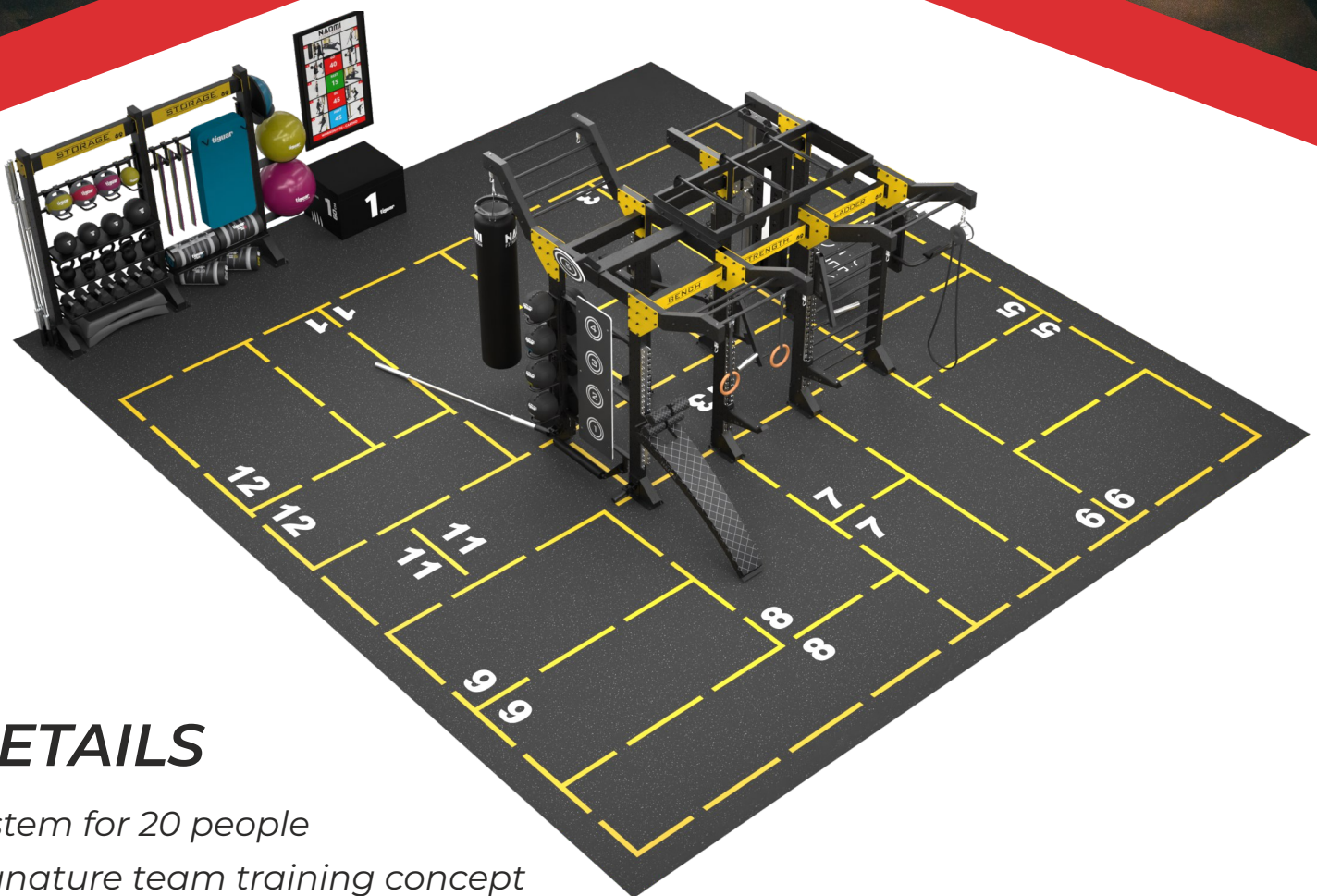

## DETAILS

*system for 20 people*

*Signature team training concept*

*Just 30minutes: cardio, core, mobility workouts*

*90sqm flooring - 67sqm workout zone*

*9 x 10 metters ( + 24cm each side for slope )*

# 10X TRAINING

## X400

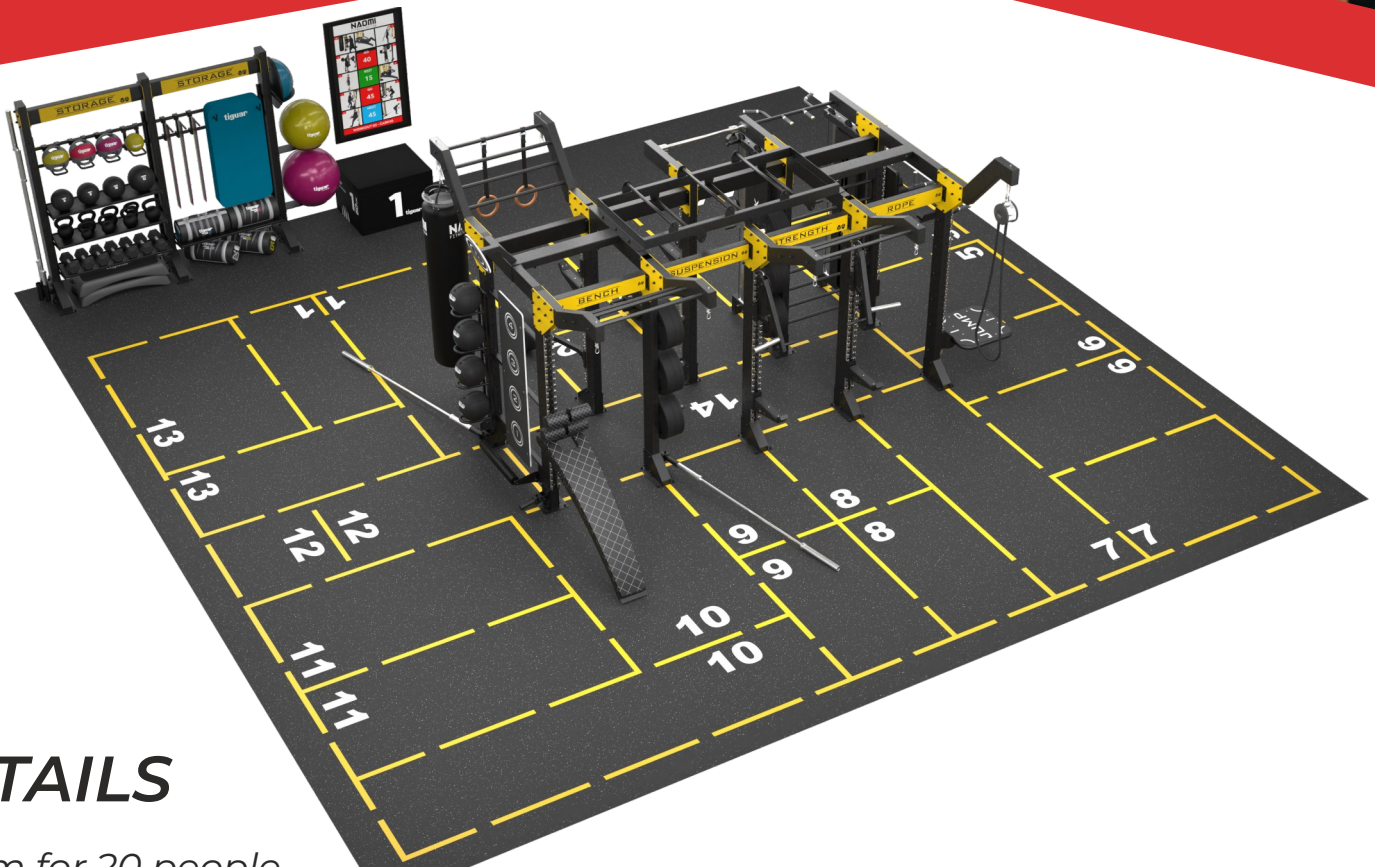

## DETAILS

*system for 20 people*

*Signature team training concept*

*Just 30minutes: cardio, core, mobility workouts*

*100sqm flooring 10 x 10 metters ( + 24cm each side for slope )*

**UCPA Lyon**

---



**Xtreme Fitness Gyms**

---



**Victory Fitness**

---



**Moulineaux Sports City stadium**

---



**Easy-gym**

---

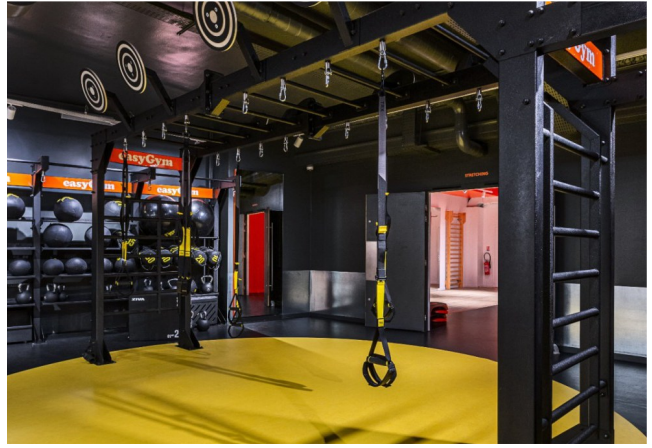

**Mix Belgium**

---



**K1 Poland**

---



**Cowool Cergy**

---



**UCPA Sport Station Bordeaux**

---

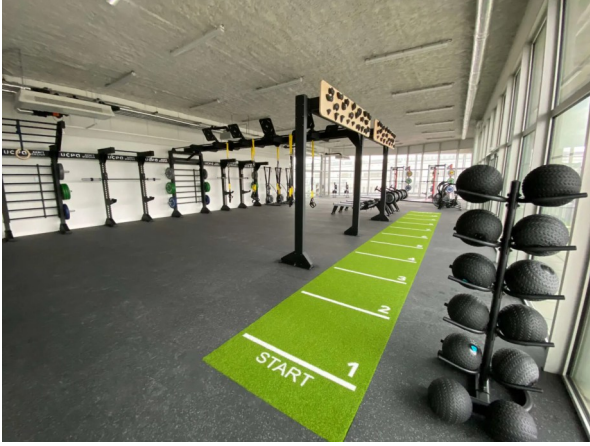

**Hyrig UK**

---



**Nolan Health Academy Ireland**

---



**Rafa Nadal Academy Kuwait**

---



**On Air Montrouge**

---



**Ukraine**

---



**California Gym Tunisia**

---



**Results Gym New York**

---



# CUSTOMS - NEXT LEVEL - BULGARIA



# ABOUT US

*Meet three fitness professionals that once upon a time had set out with one idea in mind: to create a valuable and prolific functional fitness product that spans the entire spectrum of fitness. The team recognized an opportunity to create a functional fitness zone that provides unique attributes to better meet customer needs than many look-alike products on the market. By maintaining an efficient and buoyant business structure, we are able to be focused on listening to customers and reacting quickly with creative, innovative ideas that differentiate our products with meaningful functions and features.*

*Our leaders and team members have played integral roles for many years in the development of critical breakthroughs on functional fitness market. Technical advances found on many of our products are of proprietary designs that are patented and/or patent pending. Our client-focused environment allows us to custom make any project in accordance with the specifications of the end user.*

*Naomi Fitness Design products are driven by the recognition that it must help health club owners attract and retain members so that they survive and prosper in this challenging environment. This member/end user focus has highlighted the importance that when people will see our products when they walk out onto the exercise floor and how they will feel when they step into your facility. So every product is hard wired into this simple but laser focused design philosophy.*

*Naomi Fitness Design mission is to provide the world's best and most state-of-the-art functional fitness exercise equipment for people of all ages and activity levels who aspire to live stronger and play harder and better.*

*We take immense pride in our production process. Crafted in Poland, our equipment utilizes highly durable materials that meet EU Standards, guaranteeing that our cages withstand the test of time and heavy use.*

*Our mission is to supply the world's finest and most innovative functional fitness equipment for individuals of all ages and activity levels, inspiring them to lead longer, healthier lives and to excel in their chosen pursuits.*

***Amongst our partners are:***

*YMCA USA, Xtreme Fitness Poland, Fitness Plus Switzerland, Fitness Center Baden Switzerland, Switzerland Army Training Academy, XTRAFIT Germany, Vision Body Germany, Centiness Germany, Mickey Edwards Training Academy UK, Nolan Health & Center Enniscorthy Ireland, Health City Fitness & More Italy, Feelness Spain, Anytime Fitness Spain, Sarl Fitness Club France, Royal Danish Military Academy Denmark, Airbus France, Rafa Nadal Academy Kuwait*





[www.naomifitnessdesign.com](http://www.naomifitnessdesign.com)



+48 881 912 539



[info@naomifitness.com](mailto:info@naomifitness.com)



[facebook.com/naomifitnessdesign/](https://facebook.com/naomifitnessdesign/)



[@naomifitnessdesign](https://twitter.com/naomifitnessdesign)



[#naomifitnessdesign](https://www.instagram.com/naomifitnessdesign)



*/ SportiC  
/ Lubiejewska 96  
/ 07-300 Ostrów Mazowiecka  
/ Poland  
/ Mobile: 0048 881912 539*

